

Installation Instructions

BP760A Heavy Duty Swivel Pintle Hook

Capacity

12,000 lbs. Maximum vertical load

60,000 lbs. Maximum gross trailer weight

WARNING

Maintain adequate vertical (tongue) load to properly control the trailer (generally 10%) but do not exceed the above rated capacities.

Towing Applications

Use with trailers and equipment designed for over the road towing within the stated capacities. **Use only with non swivel-type drawbar.** This pintle hook is ideal for use in the utility and construction industries. For off-road applications, reduce the stated capacities by 25%.

Drawbar Eye Dimensions

3" I.D. with a 1-5/8" cross section.

Mounting

1. Use a mounting structure of sufficient strength to support the rated capacity to the pintle hook in accordance with S.A.E. J849B.
2. Use the hole pattern shown on the reverse side of this sheet.
3. Remove the cotter pin (FPC025000400), nut (7620), washer (7619), nuts (BP760L), bolts (3002818) and both flanges (3006564 & 3006565).
4. Use bolts and nuts provided to install mounting brackets. Install front and rear mounting brackets in the proper position and securely tighten bolts.
5. Install pintle hook, washer, and nut. Tighten nut securely but allow for swivel action, install and spread cotter pin.

Operating Instructions

1. Before operating, check for proper operation, worn, damaged, or missing parts and secure mounting bolts. Check swivel action and insure pintle has no fore and aft movement. Lubricate if swivel is not smooth. Tighten nut (7620) if fore and aft movement is detected. Replace missing or worn parts.



2. Verify pintle is in the proper coupling position as shown (latch on top).
3. Open latch (3006898) by removing safety pin (3006875) and lifting toggle and jaw assembly.
4. Lower drawbar eye over the horn of the pintle.
5. Close latch and insert safety pin.

WARNING

Other steps and inspections are also required. Consult D.O.T. regulations and American Trucking Association for complete coupling and uncoupling procedures.

Maintenance & General Information

For proper performance, perform the following every 3,000 miles or 3 months, whichever comes first.

1. Clean and inspect for proper operation.
2. Inspect for worn, loose, or missing parts. Replace missing or worn parts, and tighten all fasteners.
3. Lubricate lock pivot with a light oil lubricant, apply a small quantity of grease through the grease zerks in the mounting brackets, and latch.
4. Do not add to, or modify this product.
5. Wear safety lens during installation, removal and rebuilding.
6. Never strike any part of the item with a steel hammer.
7. Do not weld on any part of this product.

WARNING

It is the user's responsibility to be sure that the pintle hook mounting surface is capable of 4,000 lbs. vertical load and 20,000 gross trailer weight

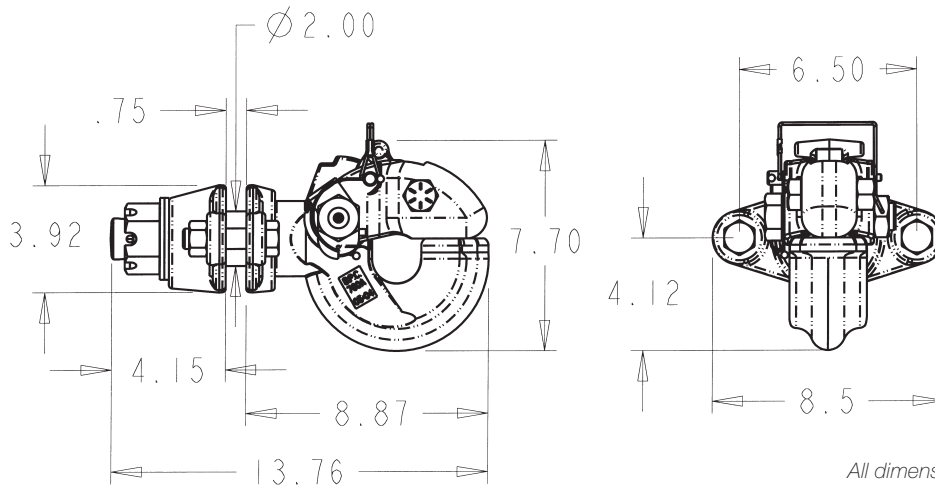
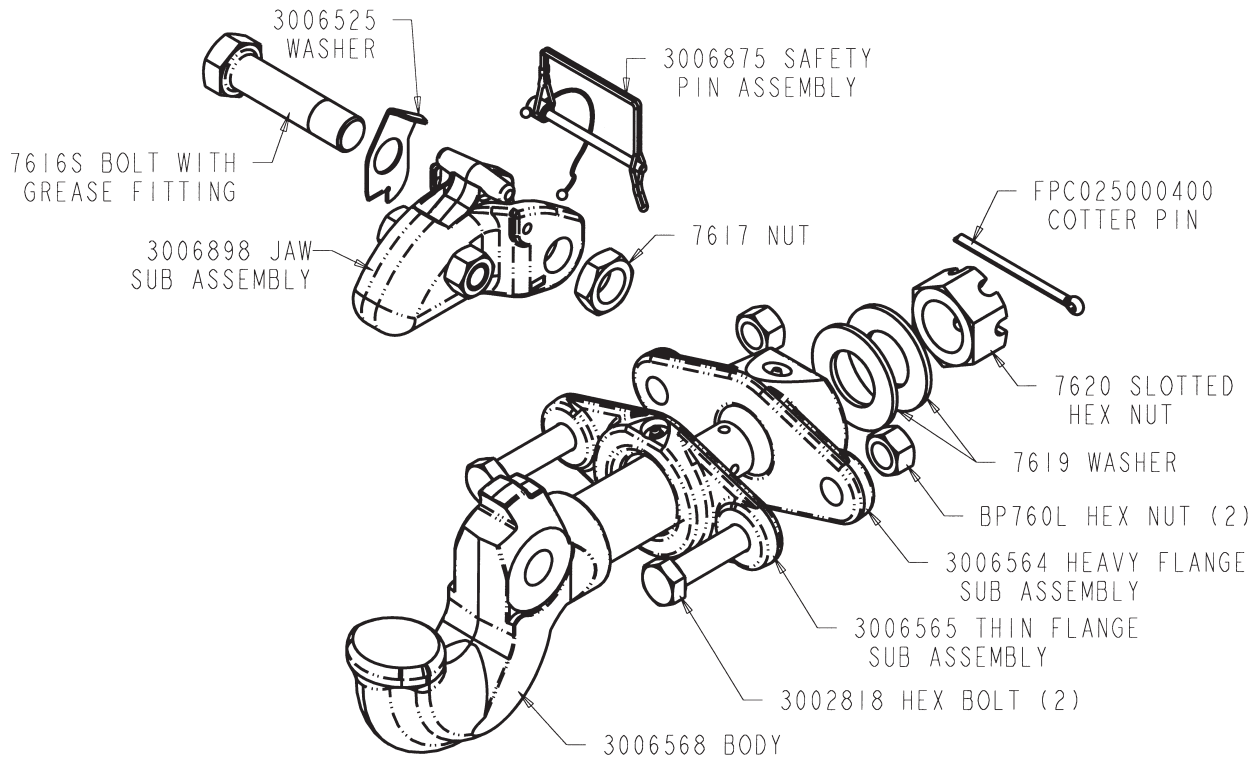

All dimensions shown are nominal.

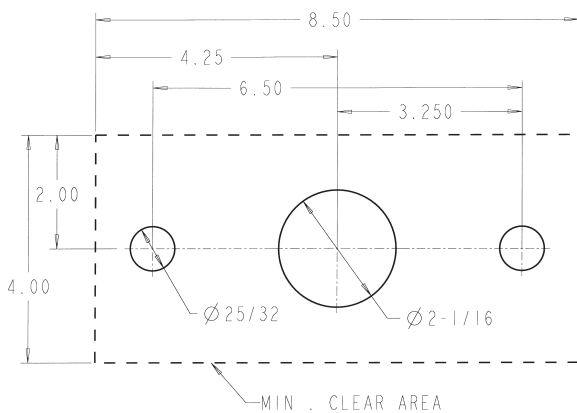

Warranty

Buyers Products Co. warrants all truck/trailer hardware manufactured or distributed by it, to be free from defects in material and workmanship for a period of one year from date of shipment. Parts must be properly installed and used under normal conditions. Any product which has been altered, including modification, misuse, accident or lack of maintenance will not be considered under warranty. Normal wear is excluded. The sole responsibility of Buyers Products Co. under this warranty is limited to repairing or replacing any part or parts which are returned, prepaid, and are found to be defective by Buyers Products Co. Authorization from Buyers Products Co. must be obtained before returning any part. No charges for transportation or labor performed on Buyers' products will be allowed under this warranty.