

REV	DESCRIPTION	DATE	APPR

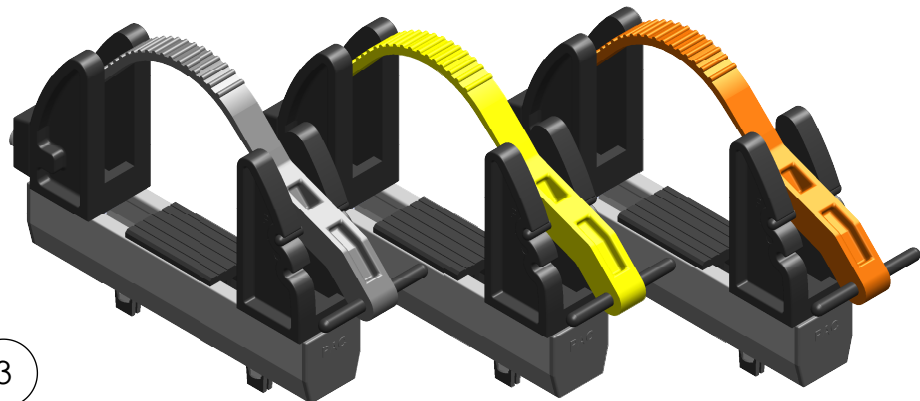

P/N K5050HDS-B P/N K5050HDS-Y P/N K5050HDS-OR

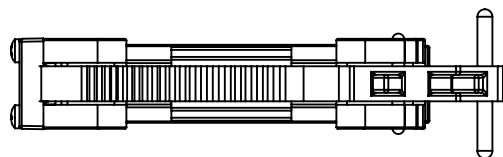

9-1/2" USABLE STRAP LENGTH

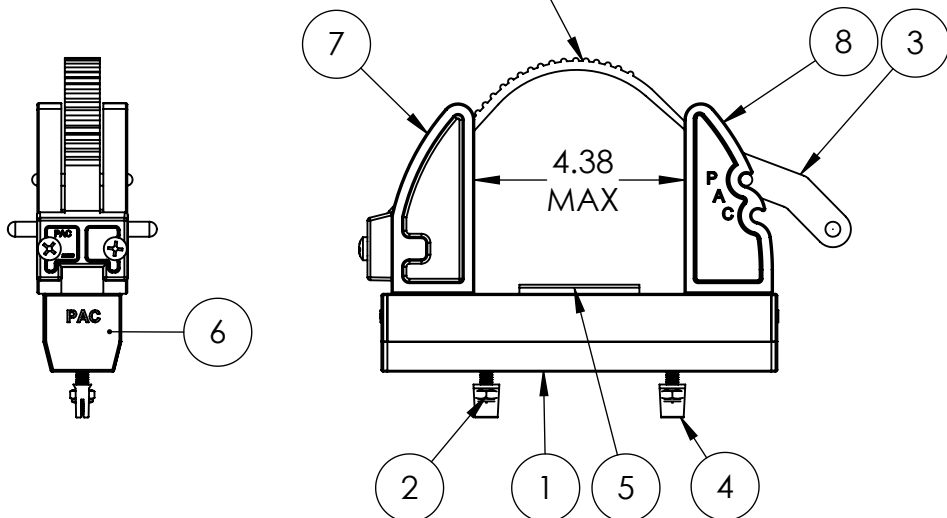

8	1050-906	SUPER ADJ. LOCK END ASSEMBLY	1	
7	1050-905	SUPER ADJ. CLAMP END ASSEMBLY	1	A
6	2020EC	END CAP PAC STRUT HD	2	
5	8006P X 2-1/2"	CHANNEL CUSHION	1	
4	7029	FASTENER KIT-ADJUSTAMOUNT PT	1	
3	2008	SAM LOCK STRAP	1	
2	2035	FASTENER PACK	1	
1	2020-8	PAC STRUT HD	1	
ITEM NO.	PAC P/N	PART NAME	QTY.	REV

NOTES:

PERFORMANCE
ADVANTAGE
COMPANY



TOLERANCES UNLESS OTHERWISE SPECIFIED

.X= ± .03
.XX= ± .010
.XXX= ± .005
.XXXX= ± 0.0005
ANGLES ± 0.5 °
FRACTIONAL ± 1/64

THIRD ANGLE PROJECTION



COLOR

	NAME	DATE
DRAWN BY		
APPR. BY		
MFG BY		
MFG. P/N		
ENG APPR.		
MATERIAL		
ALT. MATERIAL		
FINISH		

THE INFORMATION CONTAINED IN THIS DRAWING IS THE SOLE PROPERTY OF PERFORMANCE ADVANTAGE CO. ANY REPRODUCTION IN PART OR AS A WHOLE WITHOUT THE WRITTEN PERMISSION OF PERFORMANCE ADVANTAGE CO. IS PROHIBITED.

TITLE:

SUPER ADJUSTAMOUNT HD SHORT

PART NUMBER

K5050HDS

REV

SCALE: 1:4

SHEET 1 OF 3