



## BACK-UP ALARMS

### 800 SERIES Surface Mount

Designed to meet all the harsh operational requirements of any fleets equipment, ECCO's 800 Series alarms feature a reverse-mounted speaker design and reinforced nylon housing providing unrivaled durability. These alarms are so robust that an ECCOLIFE™ warranty covering the alarm for the life of the vehicle is offered on all models. These 800 Series alarm models feature a mounting bracket with the same mounting pattern popular with OEM's. Smart Alarm® models measure ambient noise and adjust their sound level, creating a volume that is safe without being annoying or contributing to noise pollution. Smart Alarms eliminate the need for constant manual adjustment and help prevent intentional alarm disconnection. Ask your local representative for any supporting documents and certifications.

#### Models

PART NO.	TYPE	CERTIFICATIONS	VOLTAGE	dB(A)	AMPS
SA907N	Smart	CE, R10, UL, IP64	12-24	82-107	0.5
SA917N	Smart	SAE Type F, CE, R10	12-24	87-112	1.5
SA914N	OEM Mounting	SAE Type F, CE, R10	12-24	87-112	1.5
840N	-	CE, R10, IP65	12-36	97/112 Switchable	1.4
830N	-	SAE Type B, CE, R10, AMECA	12-36	107	1.1
850N	-	SAE Type A, CE, R10, UL, IP65, AMECA	12-36	112	1.3
876N	OEM Mounting	SAE Type A, CE, R10, UL, AMECA	12-36	112	1.3

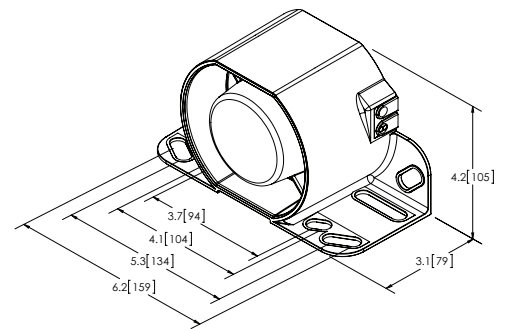

#### Alarm Specifications

Connection: 16 AWG blunt cut wires  
 Reinforced nylon housing  
 Recommended mounting bolt:  
 Bottom: 3/8-16 UNC Grade 5 or better  
 Recommended washer:  
 Bottom: 3/8" Type A Series N washer  
 Recommended mounting torque:  
 Bottom: 276 in. lbs.

#### Features and Benefits

- Mounting bracket features popular OEM footprint
- Reverse-mounted speaker enhances sound and protects the speaker from dust and moisture ingress
- Reinforced nylon housing eliminates corrosion damage
- Sealed in epoxy for protection against dust, moisture and vibration
- Temperature Range: -40°F to +185°F (-40°C to +85°C)