

Freightliner Airliner Rear Suspension Pin & Bushing Adapter

15030

**TIGER
TOOL**

Have What It Takes

Safety Warning

Read all instructions and safety warnings prior to operation. Failure to do so could result in equipment damage, personal injury, or even death.

CAUTION: KEEP HYDRAULIC COUPLER PROTECTED WHEN NOT IN USE. DUST CAPS SHOULD BE USED ON COUPLERS WHEN NOT IN USE TO AVOID CONTAMINANTS FROM ENTERING THE HYDRAULIC CYLINDER AND POWER SOURCE. THIS PRACTICE WILL HELP TO EXTEND THE LIFE OF THIS PRODUCT AND ENSURE CONTINUED CONSISTENT OPERATION.

- **Stay Alert!** Watch what you are doing and use common sense when operating this tool.
- Inspect product for damage prior to using, do not use if product is in unsafe condition.
- Do not operate tool while under the influence of drugs, alcohol, or medication.
- Always use safety equipment to prevent injuries. Approved face and eye protection must always be worn by the operator, as well as others in the work area.
- Do not overreach, keep proper footing and balance at all times.
- Dress properly. Do not wear loose clothing or jewelry. Keep your hair, clothing and gloves away from moving parts.
- Keep hands clear of all pressurized hydraulic components.
- Always ensure hoses are free from sharp bends and kinks.
- Keep your work area clean and well lit.



View demonstration videos and a complete product list at tigertool.com

Technical Support
1.800.661.4661

Freightliner Airliner Rear Suspension Pin & Bushing Adapter

15030

**TIGER
TOOL**

Have What It Takes

Operating Instructions

Bushing Removal

- 1 Disconnect and lower the rear end of the drive shaft. (only if equipped with an anti-walk style bushing. If suspension has a bushing w/o the anti-walk flange, the removal/install can be done from the outboard side only)
- 2 Remove bolt from one end of shock. **See Figure A.**
- 3 Jack up truck by frame.
- 4 Remove bolts from hanger/bushing. (Spring should fall out of hanger). **See Figure A.**
- 5 Attach socket (15001-127) on the outboard side of the bushing using one of the threaded pins (15001-125), tighten by hand with provided socket driver ensuing the pin is bottomed in the counterbore. (15001-127 socket can be installed either direction, ensure it is as close to the bushing as possible). See figure B.
- 6 Screw spacer sleeve (15001- 55) on to hydraulic cylinder. (Two flats on threaded end). **See Figure B.**
- 7 Insert pull bar (15001-3) in remaining socket (15001-126). Attach pull bar and socket to the bushing inside the frame with remaining threaded pin (15001-125), attach (15001-56) face plate, (15001-57) spacer sleeve, slide on cylinder with threaded sleeve and hand tighten the trigon nut (15001-7). **See Figure B.**
- 8 Apply hydraulic pressure-this will pull bushing approximately 2". Relieve hydraulic pressure, re-tighten trigon nut and apply pressure again. This will remove the bushing. **See Figure B.**

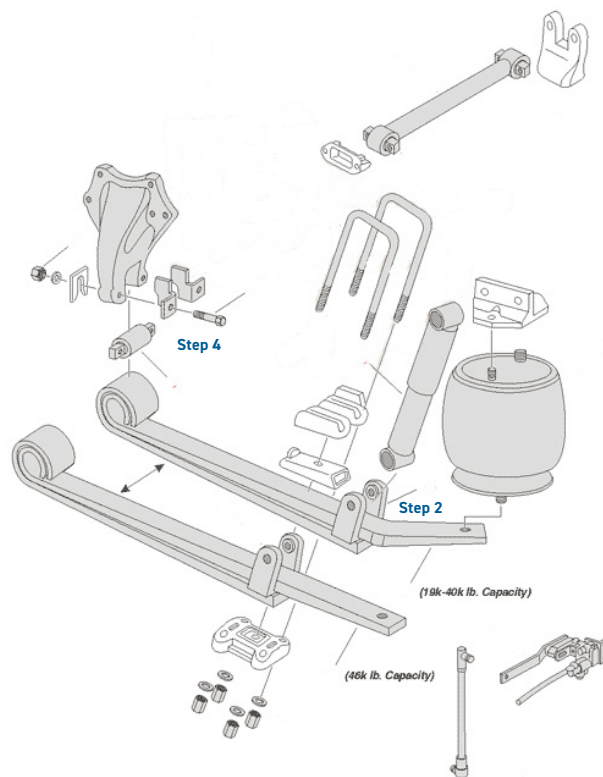

Figure A

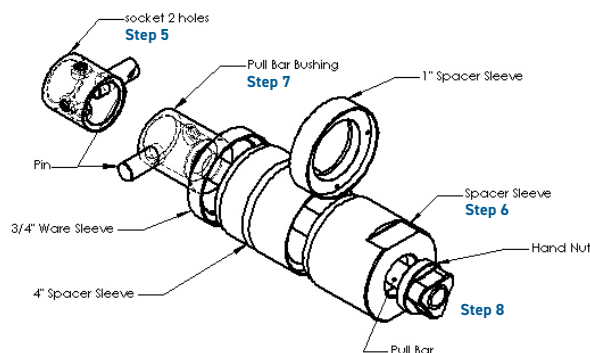

Figure B



View demonstration videos and a complete product list at tigertool.com

Technical Support
1.800.661.4661

Freightliner Airliner Rear Suspension Pin & Bushing Adapter 15030

**TIGER
TOOL**

Have What It Takes

Operating Instructions

Bushing Installation

- 1 Attach socket (15001-127) to flange side of bushing as close as possible.
- 2 Attach socket (15001-126) and pull bar (15001-3) to small side of bushing and install threaded pin (15001-125).
- 3 Slide pull bar through spring eyelet, attach face plate (15001-61) on to cylinder adapter (15001-55).
- 4 Position hydraulic cylinder and cylinder adapter /faceplate over the pull bar. Thread on the trigon nut and hand tighten.
- 5 Apply hydraulic pressure, (this will pull bushing in approximately 2"). Release pressure, snug up trigon nut and apply pressure again until the bushing is fully installed.
- 6 Remove sockets and reinstall spring in hanger.

Here at Tiger Tool, your satisfaction is our number one priority. Should you have any questions about this or any of our products, please call us at 1.800.661.4661.

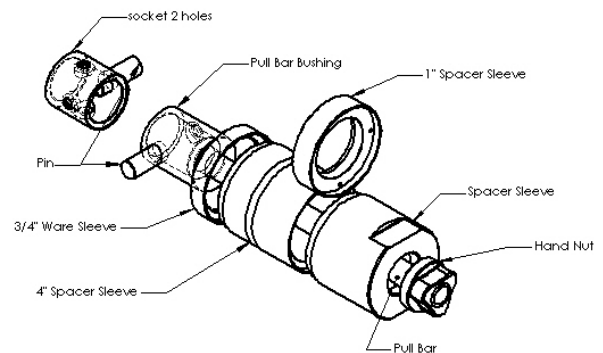

Figure C



View demonstration videos and a complete product list at tigertool.com

Technical Support
1.800.661.4661

Freightliner Airliner Rear Suspension Pin & Bushing Adapter

15030



Have What It Takes

Parts Breakdown



Item No.	Part Number	Description	Qty.
1	15001-57	Spacer Tube	1
2	15001-55	Cylinder Adapter	1
3	15001-56	3.25" Tube Cap	1
4	15001-127	Push Adapter	1
5	15001-126	Pull Adapter	1
6	15001-125	Adapter Pin	2
7	15001-61	2.625" Tube Cap	1
8	15001-9	Magnet	20
9	15030-1	.25" Socket Driver	1



View demonstration videos and a complete product list at tigertool.com

Technical Support
1.800.661.4661