

# Peterbilt Air Trac Pin & Bushing Adapter

15012

**TIGER  
TOOL**

Have What It Takes

## Safety Warning

**Read all instructions and safety warnings prior to operation. Failure to do so could result in equipment damage, personal injury, or even death.**

**CAUTION: KEEP HYDRAULIC COUPLER PROTECTED WHEN NOT IN USE.** DUST CAPS SHOULD BE USED ON COUPLERS WHEN NOT IN USE TO AVOID CONTAMINANTS FROM ENTERING THE HYDRAULIC CYLINDER AND POWER SOURCE. THIS PRACTICE WILL HELP TO EXTEND THE LIFE OF THIS PRODUCT AND ENSURE CONTINUED CONSISTENT OPERATION.

- **Stay Alert!** Watch what you are doing and use common sense when operating this tool.
- Inspect product for damage prior to using, do not use if product is in unsafe condition.
- Do not operate tool while under the influence of drugs, alcohol, or medication.
- Always use safety equipment to prevent injuries. Approved face and eye protection must always be worn by the operator, as well as others in the work area.
- Do not overreach, keep proper footing and balance at all times.
- Dress properly. Do not wear loose clothing or jewelry. Keep your hair, clothing and gloves away from moving parts.
- Keep hands clear of all pressurized hydraulic components.
- Always ensure hoses are free from sharp bends and kinks.
- Keep your work area clean and well lit.



View demonstration videos and a complete product list at [tigertool.com](http://tigertool.com)

Technical Support  
1.800.661.4661

# Peterbilt Air Trac Pin & Bushing Adapter

15012

**TIGER  
TOOL**

Have What It Takes

## Operating Instructions

### Bushing Removal

- 1 Remove torque rod from the suspension. **Figure A**
- 2 Thread on the 15001-55 cylinder adapter to the 17202 hydraulic cylinder.
- 3 Attach the 15001-79 face plate on to the 15001-57 extension tube and place the two pcs on to the 15001-55 cylinder adapter and 17202 hydraulic cylinder assembly.
- 4 Place the 15001-112 push adapter over one end of the bushing and install one 15001-125 threaded pin, hand tighten with the provided  $\frac{1}{4}$ " socket driver.
- 5 Insert the 15001-3 pull-bar through the 15001-126 pull adapter. Place the pull adapter/pull-bar over the other end of the bushing and install the remaining 15001-125 threaded pin.
- 6 Slide the hydraulic cylinder, cylinder adapter, spacer tube, face plate over the pull-bar assembly and thread on the 15001-7 trignon nut, hand tighten.
- 7 Connect your 10,000psi hydraulic pump to the cylinder and apply force until the cylinder has fully extended (approx. 2"). Release pressure and hand tighten trignon nut. Repeat until bushing is removed.
- 8 Remove adapters from the old bushing and disassemble tooling.

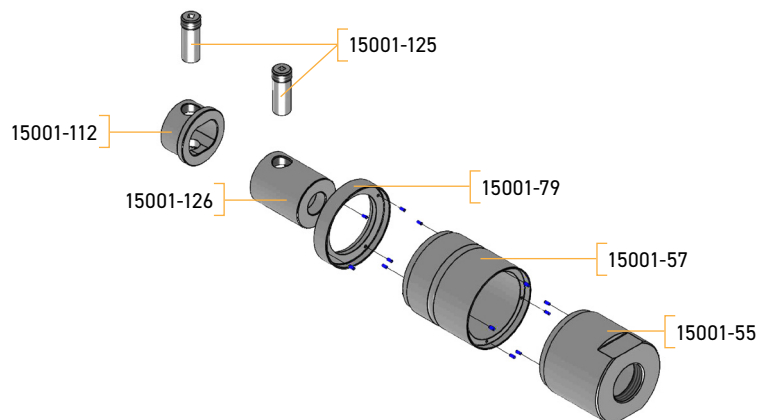
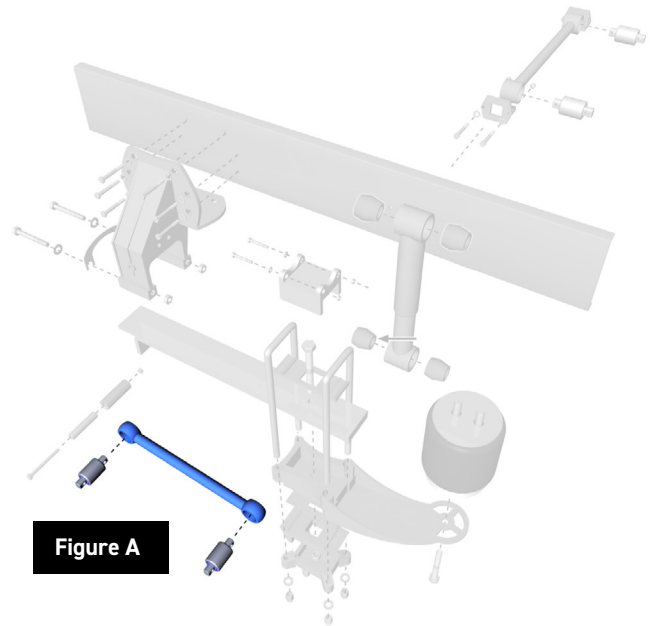

View demonstration videos and a complete product list at [tigertool.com](http://tigertool.com)

Technical Support  
1.800.661.4661

# Peterbilt Air Trac Pin & Bushing Adapter

15012

**TIGER  
TOOL**

Have What It Takes

## Operating Instructions

### Bushing Installation

- 1 Thread on the 15001-55 cylinder adapter to the 17202 hydraulic cylinder.
- 2 Attach the 15001-79 face plate to the 15001-55 cylinder adapter (the 15001-57 extension tube is not used for installation).
- 3 Place the 15001-112 push adapter on to the new bushing and install one of the 15001-125 threaded pins, tighten by hand with the provided 1/2" socket driver.
- 4 Insert the 15001-3 pull-bar through the 15001-126 pull adapter. Place the pull adapter/pull-bar over the other end of the bushing and install the remaining 15001-125 threaded pin.
- 5 Insert the pull-bar and bushing assembly through the eye of the torque rod (threaded end of the pull-bar first) until the bushing is up against the torque rod in the desired orientation.
- 6 Place the hydraulic cylinder, cylinder adapter, face plate over the pull-bar and thread on the 15001-7 trigon nut, hand tighten.
- 7 Connect your 10,000psi hydraulic pump to the cylinder and apply force until the cylinder has fully extended. Release pressure and hand tighten trigon nut. Repeat until the bushing is in desired installed depth.
- 8 Remove adapters from the bushing and disassemble tooling.

Here at Tiger Tool, your satisfaction is our number one priority. Should you have any questions about this or any of our products, please call us at 1.800.661.4661.



View demonstration videos and a complete product list at [tigertool.com](https://www.tigertool.com)

Technical Support  
1.800.661.4661

# Peterbilt Air Trac Pin & Bushing Adapter

15012



Have What It Takes

## Parts Breakdown



Part Number	Description	Qty.
15001-57	Spacer Tube	1
15001-55	Cylinder Adapter	1
15001-79	Peterbilt Air Trac Face Ring	1
15001-125	Threaded Pin	2
15030-1	.25" Socket Driver	1
15001-112	Push Adapter	1
15001-126	Pull Adapter	1
15001-9	Magnets	16



View demonstration videos and a complete product list at [tigertool.com](http://tigertool.com)

Technical Support  
1.800.661.4661