



Ramsey Winch Company

Owner's Manual

Model REP 9000

Model REP 9000X

12 Volt and 24 Volt Available

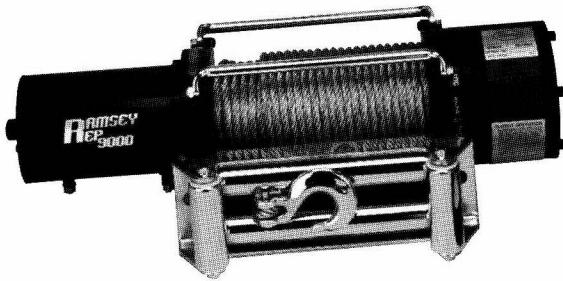

Ramsey performance data is compiled from actual winch testing.

REP 9000								
PERFORMANCE FIRST LAYER OF CABLE:					CABLE DRUM CAPACITY (5/16" (8mm) Dia. Cable) CUMULATIVE BY LAYER			
LINE PULL		LINE SPEED (Approx.)		CURRENT (Approx.) (AMP)		Layer	Ft*	M*
(lbs.)	(kgs.)	12V (FPM)	24V (MPM)	12V (AMP)	24V (AMP)			
-0-	-0-	23	7.0	25	7.6	1	15	4
2,000	900	12	3.6	15	4.5	2	40	12
4,000	1,810	8	2.4	11	3.3	3	70	21
6,000	2,710	5	1.5	9	2.7	4	95	28
9,000	4,070	2	0.6	7	2.1			

*Depends on cable being uniformly wound onto drum.

REP 9000X								
PERFORMANCE FIRST LAYER OF CABLE:					CABLE DRUM CAPACITY (5/16" (8mm) Dia. Cable) CUMULATIVE BY LAYER			
LINE PULL		LINE SPEED (Approx.)		CURRENT (Approx.) (AMP)		Layer	Ft*	M*
(lbs.)	(kgs.)	12V (FPM)	24V (MPM)	12V (AMP)	24V (AMP)			
-0-	-0-	23	7.0	25	7.6	1	15	4
2,000	900	12	3.6	15	4.5	2	35	10
4,000	1,810	8	2.4	11	3.3	3	60	18
6,000	2,710	5	1.5	9	2.7	4	90	27
9,000	4,070	2	0.6	7	2.1	5	120	36
						6	150	45

*Depends on cable being uniformly wound onto drum.

Congratulations

You have purchased the finest winch available in its service class. It features a highly efficient 3 stage planetary gear set which transmits torque from a series wound D.C. motor. A safe positive clutch allows free spooling for quick cable deployment. An automatic load holding brake is designed to hold the full rated capacity of the winch. It was designed and manufactured to provide you with the utmost in utility. As with any device that combines power and movement in its use, there are dangers if improperly used. At the same time, there are easier and faster ways for getting the job done if certain precautions are taken first. Please read this manual carefully. It contains useful ideas in obtaining the most efficient operation from your Ramsey Winch and safety procedures you need to know before beginning use. When you follow our guidelines for operation, your Ramsey Winch will give you many years of satisfying service. Thank you for choosing Ramsey. You will be glad you have one working for you.

Contents

Safety Precautions.....	2
Tips For Safe Operation.....	2
Techniques of Operation.....	3
Installation	4
Operating Instructions.....	5
Electrical Connections and Operations	5
Lubrication/Cable Installation.....	5
Troubleshooting Guide.....	6
Winch Parts List.....	7-8
Solenoid Parts List/Fairleads & Switch	9-10
Accessory Information.....	11
Warranty.....	Back Cover

Please Note: Ramsey REP 9000/REP 9000X Series winches are designed for front mount vehicle use. The winches are not designed for and should not be used in industrial applications (car haulers/carriers, wreckers, hoisting, etc.), and Ramsey does not warrant them to be suitable for such use. Ramsey makes a separate, complete line of winches for industrial/commercial use. Please contact the factory for further information.

CAUTION: Read and understand this manual before installation and operation of winch. See safety precautions.



Safety Precautions

To Guard Against Possible Injury...

A minimum of five wraps of cable around the drum barrel is necessary to hold the rated load. Cable clamp is not designed to hold the load.

- A. Keep yourself and others at a safe distance to the side of the cable when pulling under load.
- B. Don't step over a cable, or near a cable under load.
- C. Use supplied hook strap when handling hook for spooling wire rope.
- D. Don't move the vehicle to pull a load on the winch cable. This could result in cable breakage.
- E. Use a heavy rag or gloves to protect hands from burrs when handling winch cable.
- F. Apply blocks to wheels when vehicle is on an incline.
- G. Winch clutch should be disengaged when winch is not in use and fully engaged when in use.
- H. Modification, alteration, or deviation to the winch should only be made by Ramsey Winch Company.
- I. Keep the duration of your pulls as short as possible. If the motor become uncomfortably hot to the touch, stop and let it cool for a few minutes. Do not pull more than one minute at or near rated load. Do not maintain power to the winch if the motor stalls. Electric winches are for intermittent usage and should not be used in constant duty applications.
- J. Disconnect the remote control switch from the winch when not in use. A Ramsey Part no. 282053 safety on-off switch in your vehicle is recommended.
- K. *Note:* Do not use winch in hoisting applications due to required hoist safety factors and features.
- L. Do not exceed maximum line pull ratings shown in tables. Shock loads must not exceed these ratings.
- M. To respool correctly, it is necessary to keep a slight load on the cable. This is accomplished by (wearing gloves) holding the cable with one hand and the remote control switch in the other, starting as far back and in the center as you can. walking up keeping the load on the cable as

the winch is powered in. Do not allow the cable to slip through your hand and do not approach the winch too closely. Turn off the winch and repeat the procedure until all the cable except a few feet is in. Disconnect the remote control switch and finish spooling in cable by rotating the drum by hand with clutch disengaged. On hiddel winches, spool in cable under power using supplied hook strap.



Tips for Safe Operation

Don't underestimate the potential danger in winching operations. Neither should you fear them. Do learn the basic dangers and avoid them.

The uneven spooling of cable, while pulling a load, is not a problem, unless there is a cable pileup on one end of drum. If this happens, reverse the winch to relieve the load and move your anchor point further to the center of the vehicle. After the job is done you can unspool and rewind for a neat lay of the cable.

Store the remote control switch inside your vehicle where it will not become damaged. Inspect it before you plug it in.

When ready to begin spooling in, plug in remote control switch with clutch disengaged. Do not engage clutch with motor running.

Never connect the hook back to the cable. This causes cable damage. Always use a sling or chain of suitable strength as shown in the illustration.

Observe your winch while winching, if possible, while standing at a safe distance. If you use vehicle drive to assist, stop and get out every few feet to assure the cable is not piling up in one corner. Jamming cable can break your winch.

Do not attach tow hooks to winch mounting apparatus. They must attach to vehicle frame.

When double lining during stationary winching, the winch hook should be attached to the chassis of the vehicle.

Since the greatest pulling power is achieved on the innermost layer of your winch, it is desirable to pull off as much line as you can for heavy pulls (remember, you must leave 5 wraps min. on the drum). If this is not practical, use a snatch block and double line arrangement (see illustration).

Neat, tight spooling avoids cable binding which is caused when a load is applied and the cable is pinched between two others. If this happens, alternately power the winch in and out a few inches. Do not attempt to work a bound cable under load, free by hand.

Techniques of Operation

The best way to get acquainted with how your winch operates is to make a few test runs before you actually need to use it. Plan your test in advance. Remember you hear your winch as well as see it operate. Get to recognize the sound of a light steady pull, a heavy pull, and sounds caused by load jerking or shifting. Soon you will gain confidence in operating your winch and its use will become second nature with you.

Your winch will not only pull your vehicle up or ease your vehicle down a steep grade, it will also pull another vehicle or a load while your vehicle is anchored in a stationary position. The sketches on this page show you a few techniques.

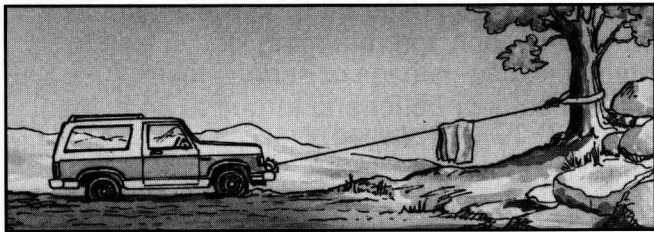

For basic self recovery, anchor to a tree or heavy rock. When anchoring to a tree, always use a tree trunk protector.



Stakes driven in solid earth and chained together make a good anchor point for self recovery when no solid anchor point is available.

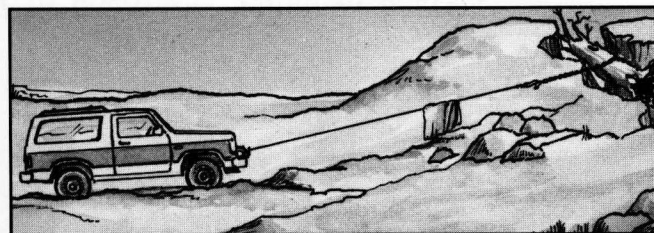

For a solid anchor, bury a log with earth or sand or place it in a deep ravine.

When pulling a heavy load, place a blanket, jacket or tarpaulin over the cable five or six feet from the hook. It will slow the snap back in the event of a broken cable. Also open the vehicle hood for additional protection.

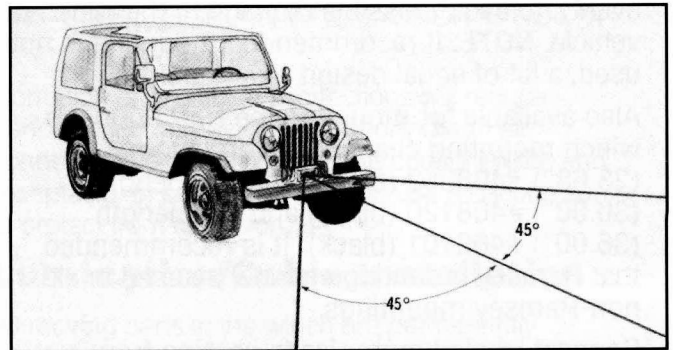

Winches equipped with cable guide fairleads can pull from several directions. Pull from an angle only to straighten up the vehicle—otherwise you can damage structural members or other parts of your vehicle and cause excess cable buildup on one end of the winch drum.

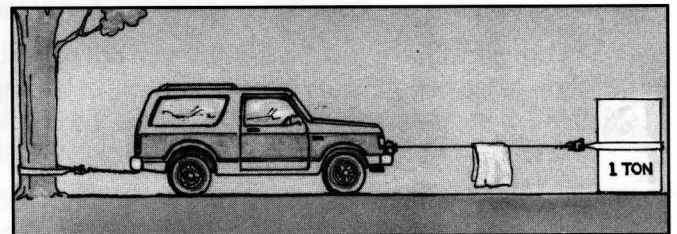

For a direct pull of 2,000 lbs., hitch truck to a tree or solid anchor, and take out of gear.

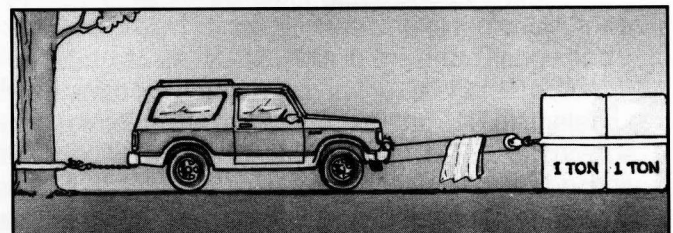

To double the pull, use 2-part line and tie off to chassis. Take out of gear.

Use the vehicle wheel power to help the winch, but don't overtake the winch line. Plan your pull. You can't always hook up and pull out in one step. Examine all the areas for anchoring possibilities as well as leverage situations, direction, and goal.

Installation

The winches shown in this owners manual are solely and exclusively designed for vehicle mounted, non-industrial applications. All other applications will void warranty.

It is very important that the winch be mounted on a flat surface so that the three major sections (the motor end, the cable drum, and the gear housing end) are properly aligned. It is recommended that Ramsey kits be used to mount the winch. They are designed to align the winch and distribute up to the full rated load evenly, to avoid possible damage to the winch or vehicle. **NOTE:** If recommended mounting is not used, a kit of equal design must be used.

Also available for mounting the REP 9000 are winch mounting channels, short length (23.63") #408052 (black), medium length (30.00") #408120 (black) and long length (36.00") #408101 (black). It is recommended that Ramsey mounting channel be used in all non-Ramsey mountings.

Connect labeled motor leads coming from solenoid assembly to appropriately marked motor terminals. When mounting winch to Ramsey kit

or channel, remove nut from tie bar mounting screw and attach ground wire to mounting screw. **TIGHTEN NUTS ON MOTOR TERMINALS AND TIE BAR NUT SECURELY** (see FIGURE 1). Use solenoid clamp, as shown in FIGURE 2, to secure solenoid assembly to winch motor. If installing in combo mounting kit, position at about a 45° angle for clearance of lower winch guard tube in kit. Be sure that clamp is clear of motor terminals at bottom of motor. **TIGHTEN CLAMP SECURELY.**

Attach fairlead to channel using hardware furnished with winch (see FIGURE 3). Attach winch to channel. Place (4) flatwashers and nuts into pockets of winch mounting feet and thread capscrews with lockwashers through mounting holes in channel and into hardware in winch feet.

Substitution of attaching hardware items (bolts, nuts or washers) different from those supplied with your winch and mounting kit can lead to failure causing damage or serious injury (use SAE grade 5 bolts or better and torque to 34 ft. lbs.).

Place end of wire rope through fairlead and attach cable hook. Use clevis pin and cotter pin (see FIGURE 3).

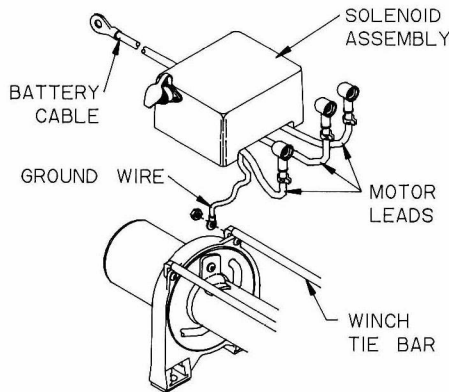

FIGURE 1

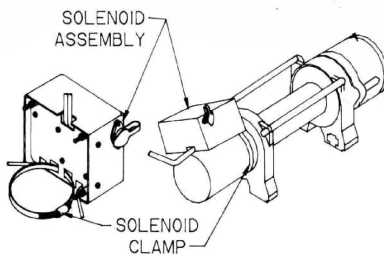

FIGURE 2

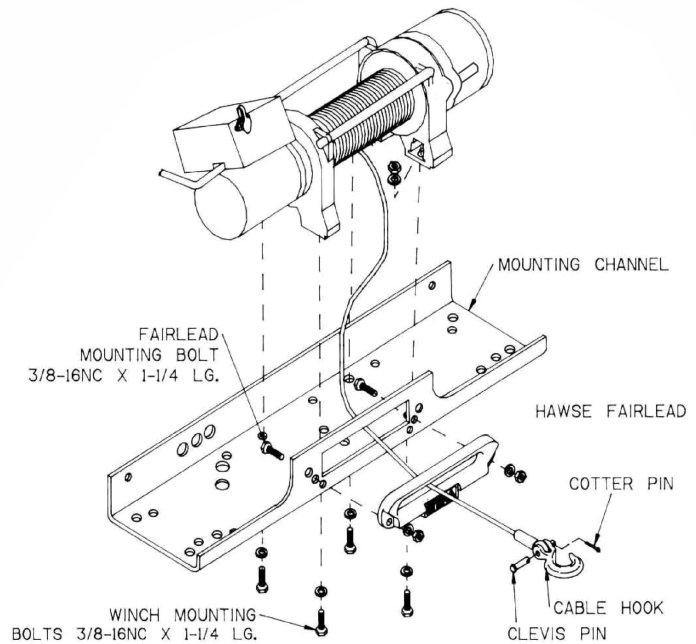

FIGURE 3

Operating Instructions

The winch clutch allows rapid unspooling of the wire rope for hooking onto the load or anchor point. The clutch is operated by the shifter tab located on the gear housing end of the winch as follows:

1. To disengage the clutch, move the clutch shifter tab to the "OUT" position. Wire rope may now be free-spooled off the drum.
2. To engage the clutch, move the clutch shifter tab into the "IN" position. The winch is now ready for pulling.

Electrical Connections and Operations

For normal self recovery work, your existing electrical system is adequate. Your battery must be kept in good condition. A fully charged battery and proper connections are essential. Run the vehicle engine during winching operations to keep battery charged.

Route battery cables up to battery. **CAUTION: BE SURE BATTERY CABLES ARE NOT DRAWN TAUT ACROSS ANY SURFACES WHICH COULD POSSIBLY DAMAGE THEM.** Connect red cable to positive (+) battery terminal (see FIGURE 1). Connect black ground cable to negative (-) terminal of battery and to winch mounting bolt on motor end of winch, as shown below.

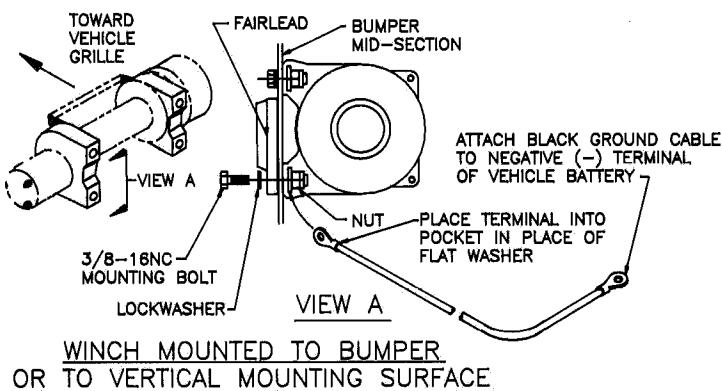
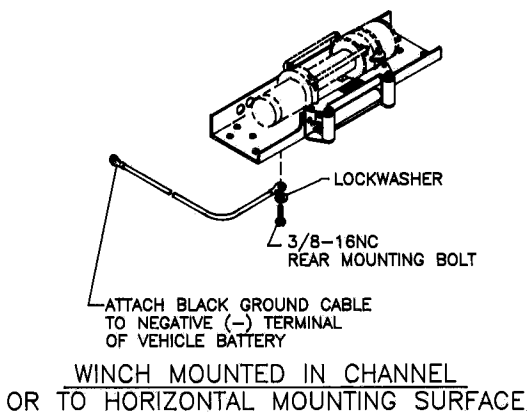

The remote control switch is water proof. It has push button stations on either side. It is designed this way to prevent quick winch reversals which lead to solenoid failure. Make sure the motor has stopped fully before reversing. To actuate winch simply plug remote control switch into receptacle in black solenoid cover of winch. Run winch forward and reverse to check connection and to determine winch operating directions. Snap appropriate "IN" and "OUT" disc into proper thumb cavity. The switch is also color coded to aid you in not having to guess at the direction your winch will run. **DO NOT LEAVE SWITCH PLUGGED IN WHEN WINCH IS NOT IN USE.**

Corrosion on electrical connections will reduce performance or may cause a short. Clean all connections especially in remote control switch and receptacle. In salty environments use a silicone sealer to protect from corrosion.

Lubrication/Cable Installation

All moving parts in the winch are permanently lubricated with high temperature lithium grease at the time of assembly. Under normal conditions factory lubrication will suffice. Lubricate cable periodically using light penetrating oil. Inspect for broken strands and replace if necessary with Ramsey part number listed in Parts List. If the cable becomes worn or damaged, it should be replaced.

Unwind the new cable by rolling it out along the ground to prevent kinking. Remove old cable and observe the manner in which it is attached to the cable drum flange.

Before installing the new cable assembly, securely wrap the end of the cable with plastic tape or similar tape to prevent fraying.

Position the cable drum so that the large 13/32" diameter hole in the motor end drum flange is approximately on the top. Form a short bend (approximately 1/2" long) in the end of the cable. Insert the bend into the 13/32" hole in the drum flange and then carefully run the winch in the "reel in" direction approximately 3/4 revolution until the 1/4" diameter threaded hole in the drum flange is on top. Secure the cable to the drum flange using item #30 cable anchor and item #19 capscrew shown in the parts drawing on Page 7. Securely tighten the capscrew, but do not over-tighten.

Wind 5 wraps of cable onto the drum. Wind on the rest of the cable by pulling in a light load to keep the tension constant. Allow the cable to swivel by using a length of chain or a swivel block between the cable hook and the load.

Ramsey Electric Winches Troubleshooting Guide

CONDITION	POSSIBLE CAUSE	CORRECTION
MOTOR RUNS IN ONLY ONE DIRECTION	(1) Defective solenoid or stuck solenoid (2) Defective remote control switch	(1) Jar solenoid to free contacts. Check by applying 12 volts to coil terminal (it should make an audible click when energized). (2) Disengage winch clutch, remove remote control switch plug from the socket and jump pins at 8 and 4 o'clock. Motor should run. Jump pins at 8 and 10 o'clock. Motor should run.
MOTOR RUNS EXTREMELY HOT MOTOR RUNS, BUT WITH INSUFFICIENT POWER, OR WITH LOW LINE SPEED	(1) Long period of operation (2) Insufficient battery (3) Bad connection (4) Insufficient charging system	(1) Cooling-off periods are essential to prevent overheating. (2) Check battery terminal voltage under load. If 10 volts or less, replace or parallel another battery to it. (3) Check battery cables for corrosion; clean and grease. (4) Replace with larger capacity charging system.
MOTOR RUNS, BUT DRUM DOES NOT TURN	(1) Clutch not engaged	(1) If clutch engaged but symptom still exists, it will be necessary to disassemble winch to determine cause and repair.
MOTOR WILL NOT OPERATE	(1) Defective solenoid or stuck solenoid (2) Defective remote control switch (3) Defective motor (4) Loose connections	(1) Jar solenoid to free contacts. Check solenoid by applying 12 volts to coil terminal (it should make an audible click when energized). (2) Disengage winch clutch, remove remote control switch plug from the socket and jump pins at 8 and 4 o'clock. Motor should run. Jump pins at 8 and 10 o'clock. Motor should run. (3) If solenoids operate, check for voltage at armature post; replace motor. (4) Tighten connections on bottom side of hood and on motor.
MOTOR WATER DAMAGED	(1) Submerged in water or water from high pressure car wash	(1) Allow to drain and dry thoroughly, then run motor without load in short bursts to dry windings.

REP 9000

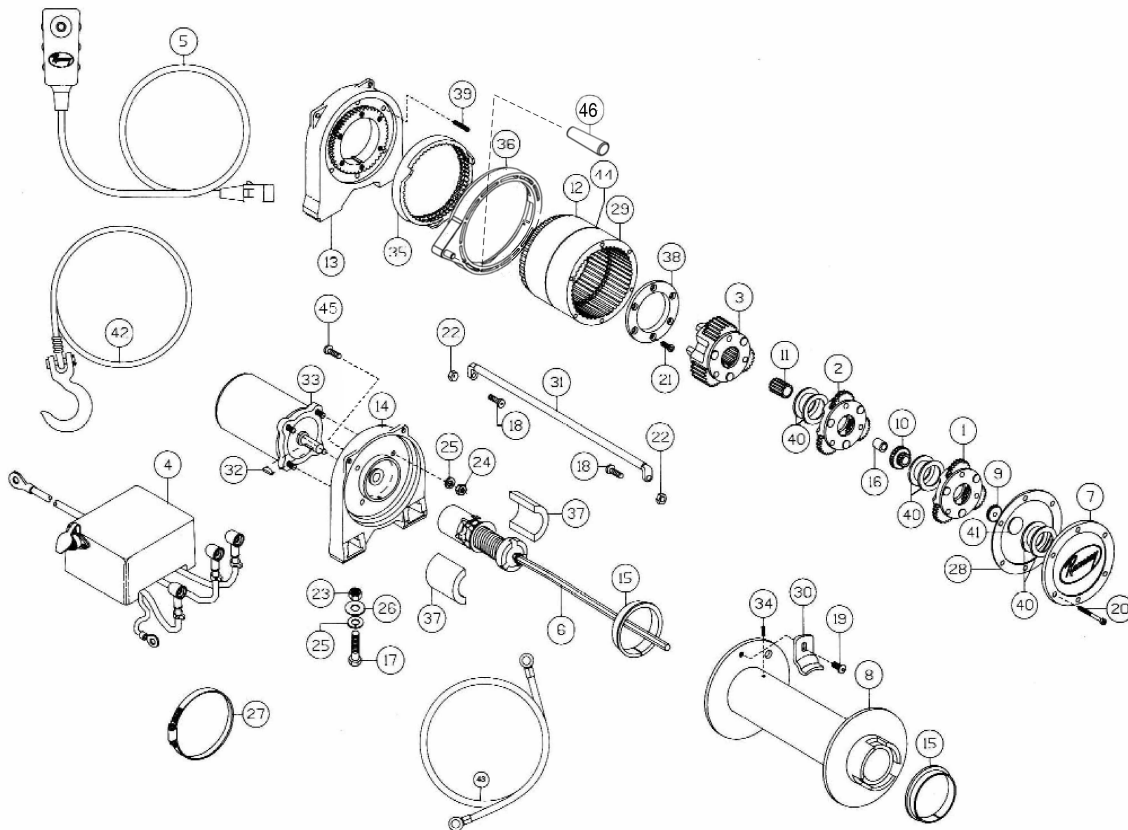

Winch Parts List REP 9000 (12V & 24V)

Item No.	Qty. Req'd	Part No.	Description	Item No.	Qty. Req'd	Part No.	Description
1	1	247009	Gear Carrier Ass'y. - Input	24	4	418040	Nut 3/8-24NF Hx Reg. Z/P
2	1	247022	Gear Carrier Ass'y - Intermediate	25	8	418177	Lockwasher 3/8 Med Sect Z/P
3	1	247023	Gear Carrier Ass'y - Output	26	4	418181	Washer - Flat 3/8 SAE Z/P
4	1	278095	Solenoid Ass'y - 12V	27	1	424023	Clamp
	1	278096	Solenoid Ass'y - 24V	28	1	442208	Gasket - Cover
5	1	251110	Switch Ass'y	29	1	444077	Gear - Ring, Input
6	1	296385	Brake/Shaft Ass'y	30	1	448046	Cable Anchor
7	1	328138	Cover - Gear Housing	31	2	448049	Tie Bar
8	1	332154	Drum - Cable	32	1	450001	Key
9	1	334154	Gear - Input Sun	33	1	458001	Motor - Electric 12V
10	1	334147	Gear - Intermediate Sun		1	458005	Motor - Electric 24V
11	1	334197	Gear - Output Sun	34	1	470053	Roll Pin 1/8 dia. x 3/8 lg.
12	1	334171	Gear - Ring Output	35	1	477002	Locking Ring
13	1	338332	End Bearing	36	1	477013	Cam Ring
14	1	338249	End Bearing - Motor	37	2	477004	Ring - Half
15	2	412056	Bushing - Drum	38	1	479007	Retainer - Ring Gear
16	1	412061	Bushing - Shaft	39	6	494007	Spring
17	4	414316	Capscrew 3/8-16NC x 1-1/4 Hx. Hd Z/P	40	6	518020	Thrust Washer
18	4	414829	Capscrew 1/4-20NC x 1 Button Hd. F/B	41	1	518027	Thrust Disc
19	1	414830	Capscrew 1/4-20NC x 3/8 Button Hd.	42	1	251118	Cable Assembly
20	6	414159	Capscrew 5/16-18UNC x 2-1/2 Hx Hd	43	1	289141	Cable - Ground
21	6	414861	Capscrew 1/4-20NC x 3/4 Flt Hd Nylok	44	1	442219	Ring Gasket
22	4	418018	Nut 1/4-20NC Hx Elastic Stop	45	1	416212	Screw #10-24NC x 3/8 Hx Soc Hd Z/P
23	4	418035	Nut 3/8-16NC Hx Reg. Z/P	46	1	452005	Shifter Handle

REP 9000X

REP 9000X Winch Mounting

*Note: Base plate #350560 and spacers #362249 are required for use only when winch is to be mounted in Ramsey mounting channels which are included in Ramsey grille guard and original kits, or may be ordered individually.

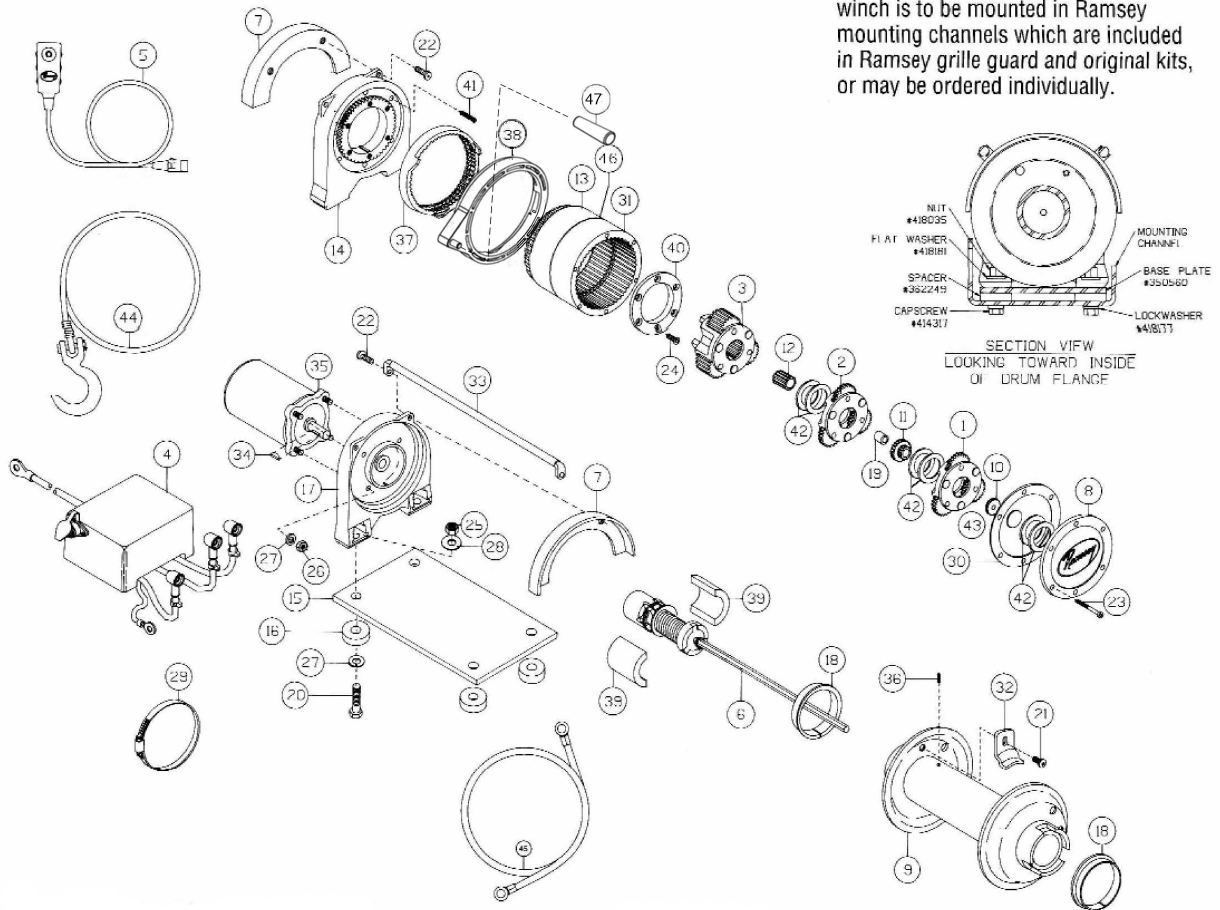

Winch Parts List REP 9000X (12V & 24V)

Item No.	Qty. Req'd	Part No.	Description	Item No.	Qty. Req'd	Part No.	Description
1	1	247009	Gear Carrier Ass'y. - Input	24	6	414861	Capscrew 1/4-20NC x 3/4 Flt Hd Nylok
2	1	247022	Gear Carrier Ass'y - Intermediate	25	4	418035	Nut 3/8-16NC Hx Reg. Z/P
3	1	247023	Gear Carrier Ass'y - Output	26	4	418040	Nut 3/8-24NF Hx Reg. Z/P
4	1	278095	Solenoid Ass'y - 12V	27	8	418177	Lockwasher 3/8 Med Sect Z/P
	1	278096	Solenoid Ass'y - 24V	28	4	418181	Washer - Flat 3/8 SAE Z/P
5	1	251110	Switch Ass'y	29	1	424023	Clamp
6	1	296385	Brake/Shaft Ass'y	30	1	442208	Gasket - Cover
7	2	328131	Shroud	31	1	444077	Gear - Ring, Input
8	1	328138	Cover - Gear Housing	32	1	448046	Cable Anchor
9	1	332154	Drum - Cable	33	2	448049	Tie Bar
10	1	334154	Gear - Input Sun	34	1	450001	Key
11	1	334147	Gear - Intermediate Sun	35	1	458001	Motor - Electric 12V
12	1	334197	Gear - Output Sun		1	458005	Motor - Electric 24V
13	1	334171	Gear - Ring Output	36	1	470053	Roll Pin 1/8 dia. x 3/8 lg.
14	1	338332	End Bearing	37	1	477002	Locking Ring
15	1	*350560	Plate - Base	38	1	477013	Cam Ring
16	4	*362249	Spacers	39	2	477004	Ring - Half
17	1	338322	End Bearing - Motor	40	1	479007	Retainer - Ring Gear
18	2	412056	Bushing - Drum	41	6	494007	Spring
19	1	412061	Bushing - Shaft	42	6	518020	Thrust Washer
20	4	414316	Capscrew 3/8-16NC x 1-1/4 Hx. Hd Z/P	43	1	518027	Thrust Disc
	4	*414317	Capscrew 3/8-16NC x 1-3/4 Hx Hd Z/P	44	1	251118	Cable Assembly
21	4	414829	Capscrew 1/4-20NC x 1 Button Hd. F/B	45	1	289141	Cable - Ground
22	1	414830	Capscrew 1/4-20NC x 3/8 Button Hd.	46	1	442219	Ring Gasket
23	6	414159	Capscrew 5/16-18UNC x 2-1/2 Hx Hd	47	1	452005	Shifter Handle

Solenoid Assembly Parts List REP 9000/REP 9000X

278095 — 12V

278096 — 24V

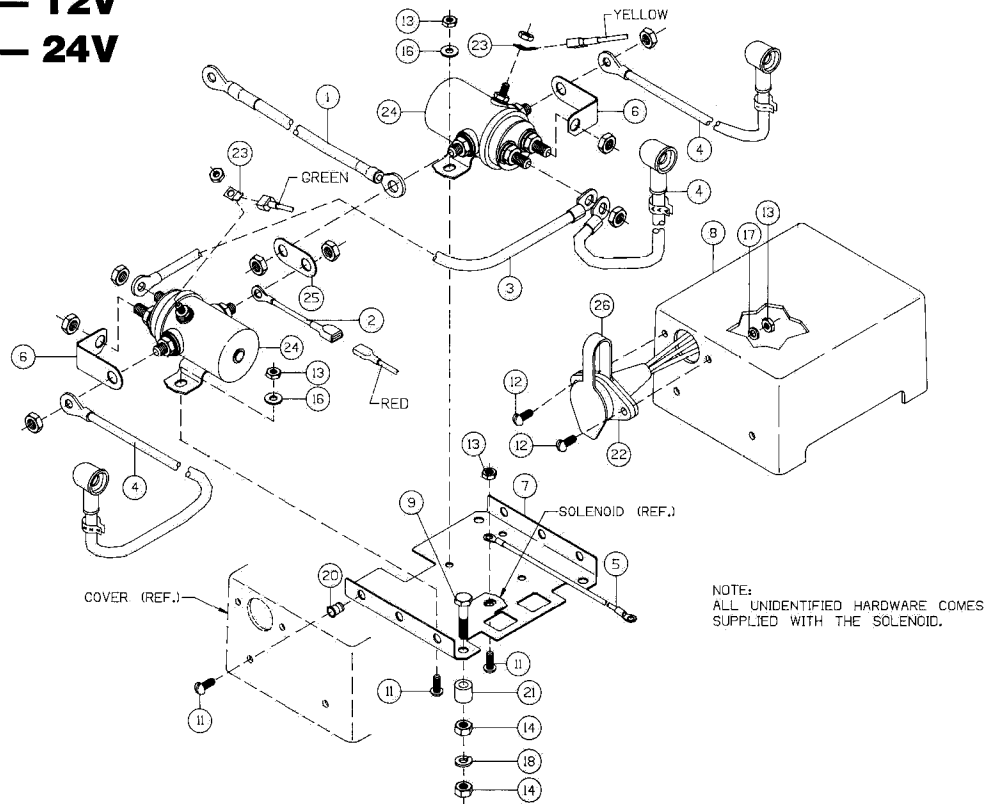

Item No.	Qty. Req'd	Part No.	Description
1	1	289015	Battery Cable
2	1	289091	Wire Assembly—Black 16 Ga. x 1½ Lg.
3	1	289092	Wire Assembly—Black 6 Ga. x 3½ Lg.
4	3	289115	Wire Assembly—Motor Lead
5	1	289121	Wire Assembly—Ground
6	2	364002	Strap—Copper
7	1	408102	Bracket
8	1	413024	Cover—Solenoid
9	3	414053	Capscrew ¼-20NC x 1¼ Lg. Hx.Hd. Z.P.
11	7	416216	Screw #10-24NC x ½ Lg. Rd. Hd. Z.P.
12	2	416227	Screw #10-24NC x ¾ Lg. Truss Hd. Black
13	6	418004	Nut—Hx. Reg. #10-24NC Z.P.
14	6	418014	Nut—Hx. Reg. ¼-20NC Z.P.
16	3	418140	Washer #10 SAE Flat Z.P.
17	2	418141	Lockwasher #10 Med. Sect. Z.P.
18	3	418149	Lockwasher ¼ Med. Sect. Z.P.
20	3	418411	Nutsert #10-24NC
21	3	418514	Spacer
22	1	430013	Connector Female—Molded
23	2	440071	Terminal Tab
24	2	440110	Solenoid—12V
	2	440114	Solenoid—24V
25	1	440111	Strap—Copper
26	1	482029	Cover—Female Connector

**Remote
Control Switch
#251110**

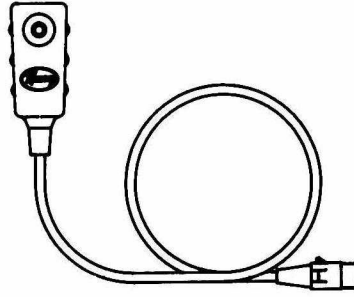

Included with: REP 9000/REP 9000X

**Hawse Fairlead
#251152**

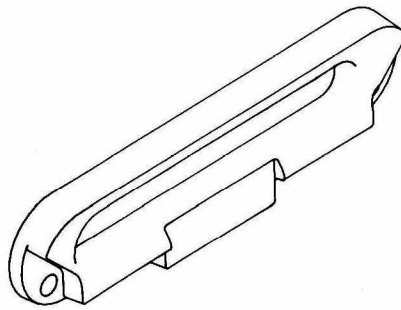

Included with: REP 9000 H/REP 9000X H

**Roller Fairlead
#251183**

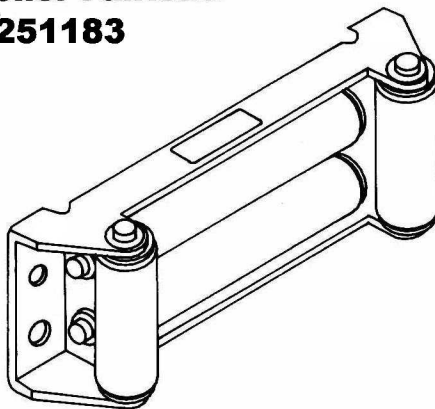

Included with: REP 9000 R/REP 9000X R

NOTES

Warranty Information

Ramsey Winches are designed and built to exacting specifications. Care and skill go into every winch we make. If the need should arise, warranty procedure is outlined on the back of your self-addressed postage paid warranty card. Please read and fill out the enclosed warranty card and send it to Ramsey Winch Company. If you have any problems with your winch, please follow instructions for prompt service on all warranty claims.

Limited Lifetime Warranty

Ramsey Winch offers a limited lifetime warranty for each new Ramsey consumer/RV winch against manufacturing defects in workmanship and materials on all mechanical components.

Warranty registration cards for each winch must be submitted at the time of purchase or within 30 days. Warranty will only be valid for the original purchaser of the winch and installed on the vehicles with which they were originally registered.

All Ramsey mounting kits and other accessories carry a 1-year limited warranty against defects in materials and workmanship.

Chrome finish warranted for one year against manufacturing defects. Cracking, scratching or corrosion caused by winching not covered by warranty.

This warranty is void if winch is used in commercial/ industrial applications, other than front mount self recovery.

Electrical components consisting of motors, solenoids, wiring, wire connectors and associated parts carry a 1-yr. limited warranty. Battery isolators carry a 90-day limited warranty.

An optional extended 2-year limited warranty for all electrical components may be purchased.

The obligation under this Warranty, statutory or otherwise, is limited to the replacement or repair at the manufacturer's factory, or at a point designated by the manufacturer, of such part as shall appear to the manufacturer, upon inspection of such part, to have been defective in material or workmanship. This Warranty does not obligate Ramsey Winch Company to bear the cost of labor or transportation charges in connection with the replacement or repair of defective parts, nor shall it apply to a product upon which repairs or alterations have been made, unless authorized by the manufacturer, or for equipment misused, neglected or improperly installed.

IMPORTANT NOTICE: To the fullest extent permitted by applicable law, the following are hereby excluded and disclaimed: 1. All warranties of fitness for a particular purpose; 2. All warranties of merchantability; 3. All claims for consequential or incidental damages. There are no warranties that extend beyond the description that appears on the face hereof.

Some states do not allow the above exclusions or disclaimers in consumer transactions and as such this disclaimer/exclusion may not apply to your particular case.

To the extent such warranties of fitness for a particular purpose or merchantability are deemed

to apply to this product, they exist for only so long as the express limited warranty elsewhere set forth is in existence.

Ramsey Winch Company makes no warranty in respect to accessories, same being subject to the warranties of their respective manufacturers.

Ramsey Winch Company, whose policy is one of continuous product improvement, reserves the right to improve any product through changes in design or materials as it may deem desirable without being obligated to incorporate such changes in products of previous manufacture.

If field service at the request of the buyer is rendered and the fault is found not to be with Ramsey Winch Company's product, the buyer shall pay the time and expense cost of the field representative. Bills for service, labor or other expenses which have been incurred by the buyer without express approval or authorization by Ramsey Winch Company will not be accepted.

This Warranty gives you specific legal rights and you may also have other legal rights which vary from state to state.



Ramsey Winch Company