

MD MOUNT KIT

16061125

FORD EXPEDITION '97-'02

FORD F-150 '97-'03

FORD F-250 LD '97-'99



SnowDogg™ Snowplow

TRUCK MOUNT INSTALLATION MANUAL

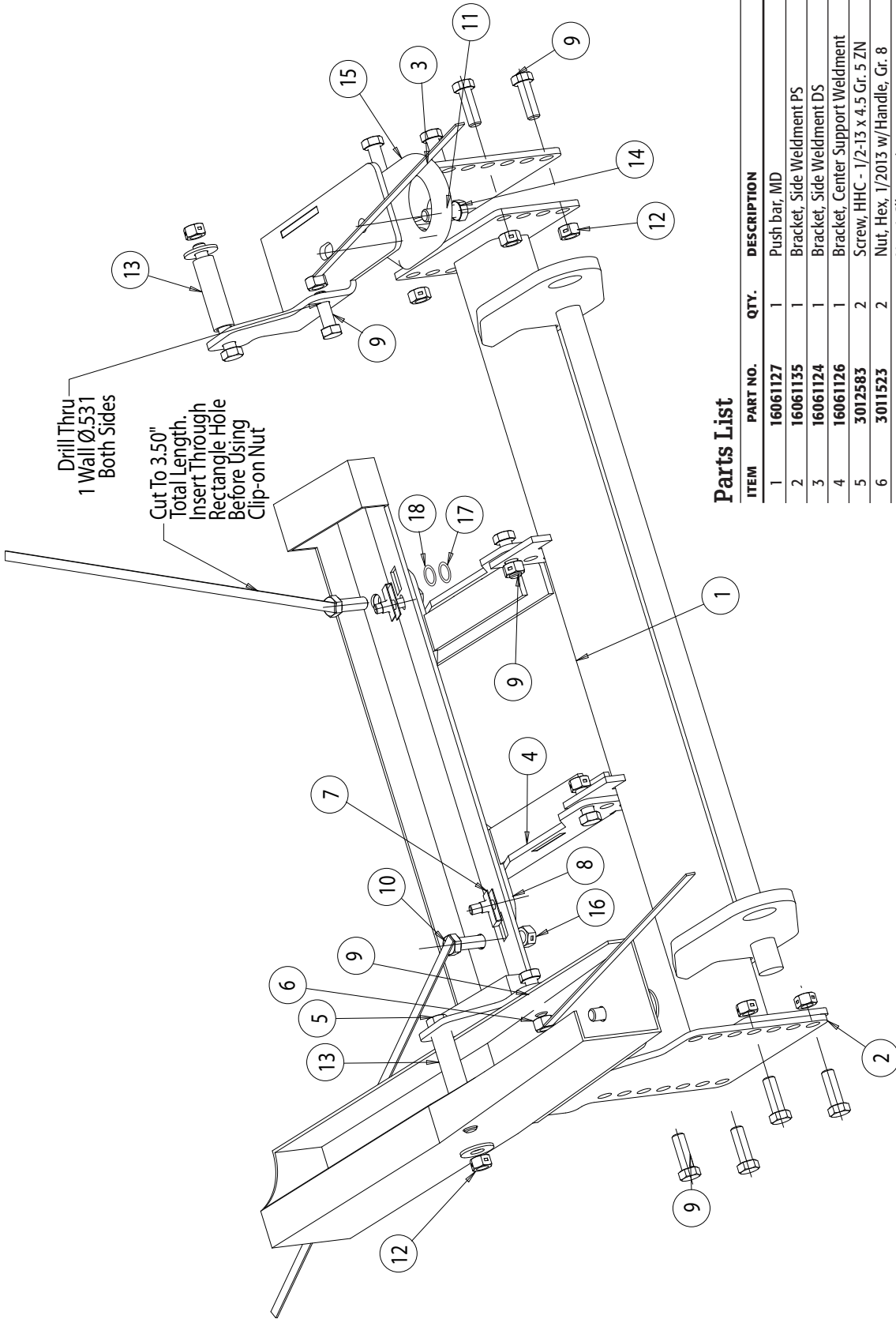

Parts List

ITEM	PART NO.	QTY.	DESCRIPTION
1	16061127	1	Push bar, MD
2	16061135	1	Bracket, Side Weldment PS
3	16061124	1	Bracket, Side Weldment DS
4	16061126	1	Bracket, Center Support Weldment
5	3012583	2	Screw, HHC - 1/2-13 x 4.5 Gr. 5 ZN
6	3011523	2	Nut, Hex, 1/2013 w/Handle, Gr. 8
7	3013849	2	Nut, J-Clip on 3/8-16
8	FCS038016150	2	Screw, Hex HD Cap 3/8-16 x 1-1/2 Gr. 5 ZN
9	3006202	14	Screw, Hex HD, 1/2-13 x 1-1/2 Gr. 8 ZN
10	16801004	2	Screw, Hex HD, 1/2-13 x 1-1/2 Gr. 5 w/HDL
11	FWF050138014	6	Washer, Flat, .500 x 1.38 x .14, ZN
12	3002397	14	Locknut, Hex 1/2013, Gr. 8 ZN
13	3013850	2	Spacer, Tubing 2.94 Long
14	-	4	Existing Fastener
15	-	1	Tow Hook
16	3006201	2	Nut, 1/2-13 Hex Gr. 8 ZP
17	FWL050088013	2	Washer, Lock, 1/2 Split, ZP
18	FWF050106010	2	Washer, Flat, 1/2" ZN

INSTRUCTIONS

1. Remove the front bumper, bumper fasteners, and skid plate. Set aside for later reinstallation.
2. Remove the tow hooks (if your vehicle option is equipped with them).
3. Hold the **PS Bracket** (2) up against the passenger side frame rail, aligning with the existing tow-hook's holes on the side of the frame. Secure the Bracket using two existing tow-hook-bolts and two **flat washers** (11).

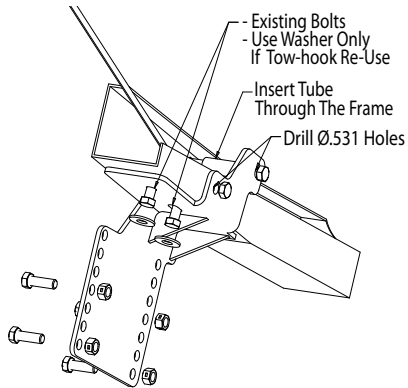

4. On the side of the frame, mark and drill the lower hole through one wall with Ø.531 hole. Mark and drill the upper hole through two walls with Ø.531 hole. Secure the **PS Bracket** (2) with one 4.5 inch bolt (5), one **flat washer** (11), one **nut w/handle** (6), and one **lock nut** (12).

Note:

Do not use the two washers if tow-hook is re-mounted with the vehicle.

5. Repeat step 3-4 above for **DS Bracket** (3).

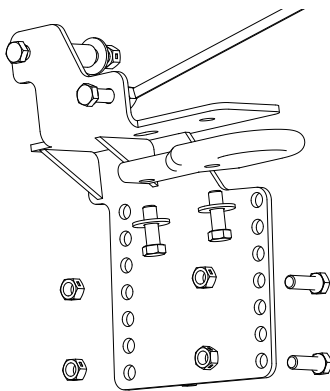

6. Mount the Pushbar (1) in place between the two side plates using eight ½-13x1-1/2 **bolts** (9), and eight **locknuts** (12). The centerline of the pushbar crosspin should be approximately 9.5" from the ground. Improper mounting height will result in uneven cutting edge wear.

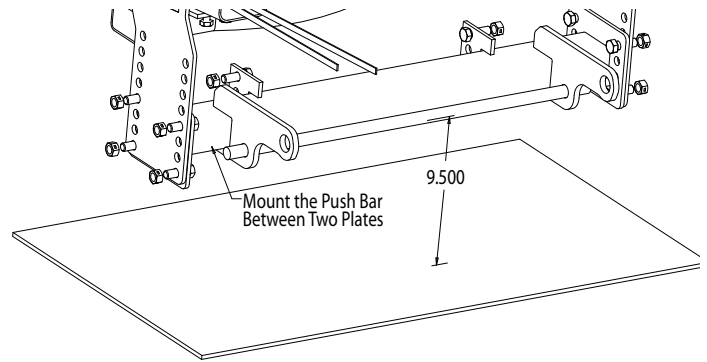

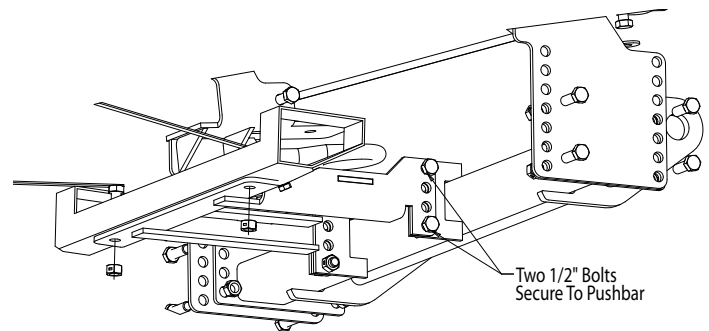

7. Install the **center support bracket** (4) to the **Push-bar** (1) using four ½-13 x 1.5 **bolts** (9) along with four **lock nuts** (12).

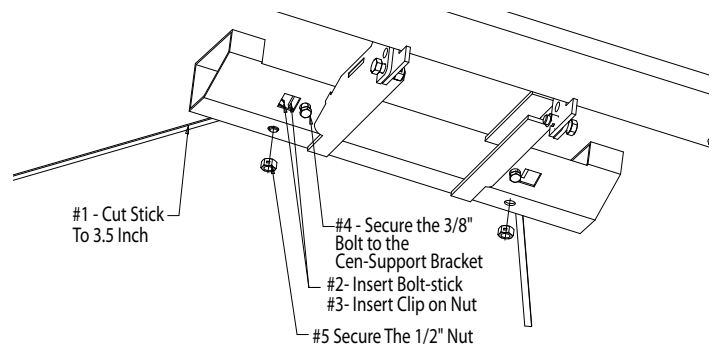

8. On the cross-member frame of the truck, insert two **clip-on nuts** (7) through the rectangle holes. Hold the **center bracket** (4) against the frame, secure it with two 3/8-16 **bolts** (8) and two ½-13 bolts with **handles** (10). The handles must be cut to 3.5 inches a head of time.



9. Torque all fasteners as shown in the chart. Check and re-torque all fasteners after 5 hours of usage to ensure safe plow operation.
10. It may be helpful to route the plow and light control harnesses at this point, prior to bumper reinstallation.
11. Reinstall the bumper/air dam assembly and skid plate. The bumper/air dam and skid plate may need to be altered or omitted for reinstallation.

Recommended Fastener Torque Chart (ft.-lb.)			
Size	 SAE Grade 2	 SAE Grade 5	 SAE Grade 8
1/4-20	6	9	13
5/16-18	11	18	28
3/8-16	19	31	46
3/8-24	24	46	68
7/16-14	30	50	75
1/2-13	45	75	115
9/16-12	66	110	165
5/8-11	93	150	225
3/4-10	150	250	370
7/8-9	150	378	591
1-8	220	583	893
Metric Grade 8.8 (ft.-lb.)			
Size	Torque	Size	Torque
M6	7	M12	60
M8	17	M14	95
M10	35	M16	155
These torque values apply to fasteners except those noted in the instruction.			

WARNING

- DO NOT under any circumstances disable, remove or relocate any sensors or components related to the operation of the air bags.
- Always follow the vehicle manufacturers' recommendations relating to snowplow installation.
- To comply with Federal Regulations and to assure a safe vehicle, the Front Gross Axle Weight Rating (FGAWR), Rear Gross Axle Weight Rating (RGAWR), and the Gross Vehicle Weight Rating (GAWR) must not be exceeded at any time.
- Due to the variety of equipment that can be installed on this vehicle, it is necessary to verify that the Front Gross Axle Weight Rating (FGAWR), Rear Gross Axle Weight Rating (RGAWR), and the Gross Vehicle Weight Rating (GAWR) are not exceeded at any time. This may require weighing the vehicle and adding ballast as necessary. It may also limit payload capacity of the vehicle. It is the operator's responsibility to verify that these ratings are not exceeded.

CAUTION

- Read all instructions prior to assembly
- It is critical that all fasteners be properly torqued for safe plow operation – see chart above.
- Fasteners should be retorqued after 5-8 hours of plow use

FULL ONE-YEAR WARRANTY

Manufacturer will repair, or at manufacturer's discretion will replace any part of this snowplow which proves to be defective in workmanship or material under normal use for a period of one year from the date of delivery to the original purchaser. Any cost incurred in returning the product to the supplier is the responsibility of the consumer.

EXCLUSIONS

Manufacturer shall not be liable for special, incidental, or consequential damages, or for damages resulting from lack of necessary maintenance, from misuse, abuse, acts of God, or alteration of the product. Some states do not allow the exclusion or limitation of incidental or consequential damages, so the above limitation or exclusion may not apply to you.