

Installation Instructions

PH30 30-Ton Pintle Hook

Capacity

15,000 lbs. maximum vertical load

60,000 lbs. maximum trailer weight

WARNING

Maintain adequate vertical (tongue) load to properly control the trailer (generally 10%) but do not exceed the above rated capacities.

Towing Applications

Trailers and equipment designed for over-the-road towing within the stated capacities. For off-road applications, reduce the capacities listed above by 25% and use in conjunction with a swivel type drawbar.

Drawbar Eye Dimension

2³/₈" to 3" I.D. with 1³/₈" to 1⁵/₈" diameter section

Mounting

1. Use a secure mounting structure of sufficient strength to support the rated capacity of the pintle hook in accordance with S.A.E. J 849B.
2. Use the hole pattern template shown on reverse side of instructions.
3. Use four 3/4" grade 8 bolts. Torque to 275 lb.-ft.

Operating Instructions

1. Before operating, check for proper operation, worn, damaged or missing parts and secure mounting. Correct flaws before use.
2. Open latch by removing safety pin, pulling plunger, and rotating latch open.
3. Position drawbar eye over the horn of the pintle and lower into place.

WARNING: Do not damage the latch. Be careful with the drawbar when coupling or uncoupling.

4. To close latch, pull plunger, rotate latch closed and release plunger. Plunger must be fully engaged to lock the latch. Assemble safety lock pin.



WARNING

Other steps & inspections are also required. Consult D.O.T. regulations & American Trucking Association for complete coupling and uncoupling procedures.

Maintenance

For proper performance, perform the following every 3,000 miles or 3 months, whichever comes first.

1. Clean and inspect for proper operation.
2. Inspect, in particular, the coupling area. Replace when wear exceeds 1/8" (.125") from the original surface profile.
3. Inspect for worn, damaged or missing parts. Replace as required.
4. Regularly lubricate latch pivot and locking plunger with a light oil lubricant.
5. Check the mounting bolts for proper torque.

General Information

1. Do not modify or add to the product.
2. Do not weld on this product.

WARNING

It is the user's responsibility to be sure that the pintle hook mounting surface is capable of 12,000 lbs. vertical load & 60,000 lbs. gross trailer weight.

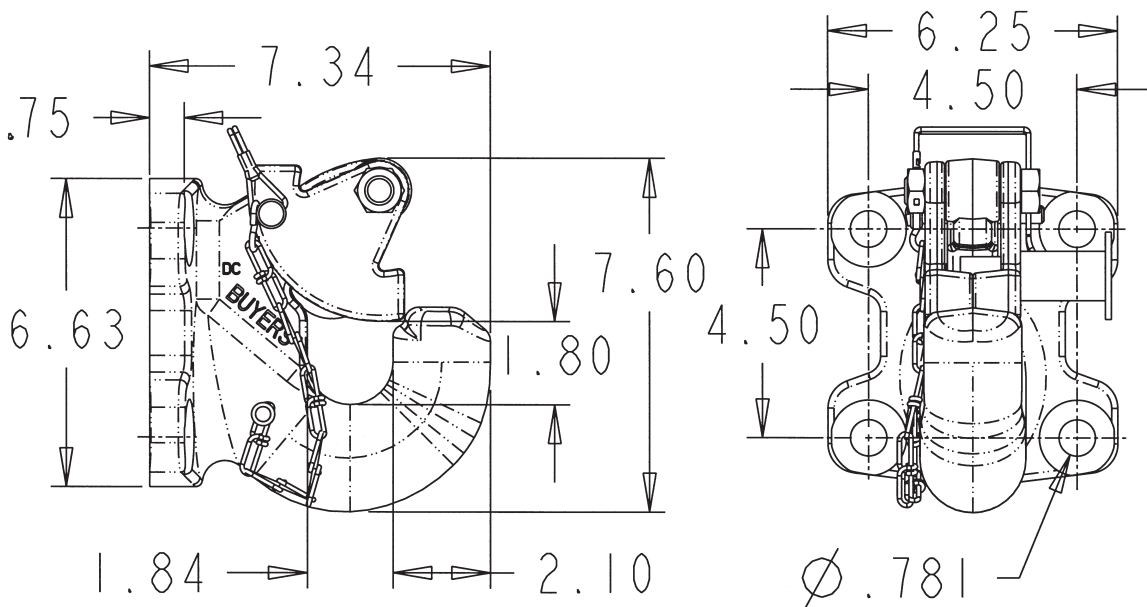

Fig. 1

All dimensions shown are nominal.

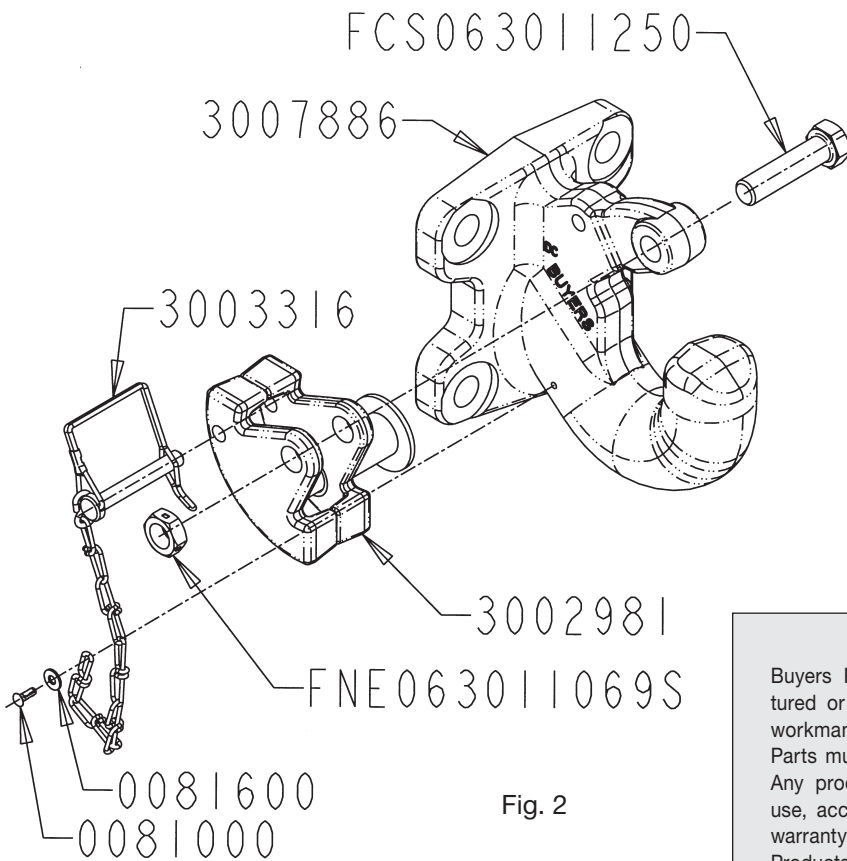

Fig. 2

Warranty

Buyers Products Co. warrants all truck/trailer hardware manufactured or distributed by it, to be free from defects in material and workmanship for a period of one year from date of shipment. Parts must be properly installed and used under normal conditions. Any product which has been altered, including modification, misuse, accident or lack of maintenance will not be considered under warranty. Normal wear is excluded. The sole responsibility of Buyers Products Co. under this warranty is limited to repairing or replacing any part or parts which are returned, prepaid, and are found to be defective by Buyers Products Co. Authorization from Buyers Products Co. must be obtained before returning any part. No charges for transportation or labor performed on Buyers' products will be allowed under this warranty.