

Warnings to Installers

Whelen's emergency vehicle warning devices must be properly mounted and wired in order to be effective and safe. Read and follow all of Whelen's written instructions when installing or using this device. Emergency vehicles are often operated under high speed stressful conditions which must be accounted for when installing all emergency warning devices. Controls should be placed within convenient reach of the operator so that they can operate the system without taking their eyes off the roadway. Emergency warning devices can require high electrical voltages and/or currents. Properly protect and use caution around live electrical connections. Grounding or shorting of electrical connections can cause high current arcing, which can cause personal injury and/or vehicle damage, including fire. Many electronic devices used in emergency vehicles can create or be affected by electromagnetic interference. Therefore, after installation of any electronic device it is necessary to test all electronic equipment simultaneously to insure that they operate free of interference from other components within the vehicle. Never power emergency warning equipment from the same circuit or share the same grounding circuit with radio communication equipment. All devices should be mounted in accordance with the manufacturer's instructions and securely fastened to vehicle elements of sufficient strength to withstand the forces applied to the device. Driver and/or passenger air bags (SRS) will affect the way equipment should be mounted. This device should be mounted by permanent installation and within the zones specified by the vehicle manufacturer, if any. Any device mounted in the deployment area of an air bag will damage or reduce the effectiveness of the air bag and may damage or dislodge the device. Installer must be sure that this device, its mounting hardware and electrical supply wiring does not interfere with the air bag or the SRS wiring or sensors. Mounting the unit inside the vehicle by a method other than permanent installation is not recommended as unit may become dislodged during swerving; sudden braking or collision. Failure to follow instructions can result in personal injury. Whelen assumes no liability for any loss resulting from the use of this warning device. **PROPER INSTALLATION COMBINED WITH OPERATOR TRAINING IN THE PROPER USE OF EMERGENCY WARNING DEVICES IS ESSENTIAL TO INSURE THE SAFETY OF EMERGENCY PERSONNEL AND THE PUBLIC.**

Warnings to Users

Whelen's emergency vehicle warning devices are intended to alert other operators and pedestrians to the presence and operation of emergency vehicles and personnel. However, the use of this or any other Whelen emergency warning device does not guarantee that you will have the right-of-way or that other drivers and pedestrians will properly heed an emergency warning signal. Never assume you have the right-of-way. It is your responsibility to proceed safely before entering an intersection, driving against traffic, responding at a high rate of speed, or walking on or around traffic lanes. Emergency vehicle warning devices should be tested on a daily basis to ensure that they operate properly. When in actual use, the operator must ensure that both visual and audible warnings are not blocked by vehicle components (i.e.: open trunks or compartment doors), people, vehicles, or other obstructions. It is the user's responsibility to understand and obey all laws regarding emergency warning devices. The user should be familiar with all applicable laws and regulations prior to the use of any emergency vehicle warning device. Whelen's audible warning devices are designed to project sound in a forward direction away from the vehicle occupants. However, because sustained periodic exposure to loud sounds can cause hearing loss, all audible warning devices should be installed and operated in accordance with the standards established by the National Fire Protection Association.

Safety First

This document provides all the necessary information to allow your Whelen product to be properly and safely installed. Before beginning the installation and/or operation of your new product, the installation technician and operator must read this manual completely. Important information is contained herein that could prevent serious injury or damage.

⚠ WARNING: This product can expose you to chemicals including Methylene Chloride which is known to the State of California to cause cancer, and Bisphenol A, which is known to the State of California to cause birth defects or other reproductive harm. For more information go to www.P65Warnings.ca.gov.

- Proper installation of this product requires the installer to have a good understanding of automotive electronics, systems and procedures.
- Whelen Engineering requires the use of waterproof butt splices and/or connectors if that connector could be exposed to moisture.
- Any holes, either created or utilized by this product, should be made both air- and watertight using a sealant recommended by your vehicle manufacturer.
- Failure to use specified installation parts and/or hardware will void the product warranty.
- If mounting this product requires drilling holes, the installer **MUST** be sure that no vehicle components or other vital parts could be damaged by the drilling process. Check both sides of the mounting surface before drilling begins. Also de-burr the holes and remove any metal shards or remnants. Install grommets into all wire passage holes.
- If this manual states that this product may be mounted with suction cups, magnets, tape or Velcro®, clean the mounting surface with a 50/50 mix of isopropyl alcohol and water and dry thoroughly.
- Do not install this product or route any wires in the deployment area of your air bag. Equipment mounted or located in the air bag deployment area will damage or reduce the effectiveness of the air bag, or become a projectile that could cause serious personal injury or death. Refer to your vehicle owner's manual for the air bag deployment area. The User/Installer assumes full responsibility to determine proper mounting location, based on providing ultimate safety to all passengers inside the vehicle.
- For this product to operate at optimum efficiency, a good electrical connection to chassis ground must be made. The recommended procedure requires the product ground wire to be connected directly to the **NEGATIVE (-)** battery post (this does not include products that use cigar power cords).
- If this product uses a remote device for activation or control, make sure that this device is located in an area that allows both the vehicle and the device to be operated safely in any driving condition.
- Do not attempt to activate or control this device in a hazardous driving situation.
- This product contains either strobe light(s), halogen light(s), high-intensity LEDs or a combination of these lights. Do not stare directly into these lights. Momentary blindness and/or eye damage could result.
- Use only soap and water to clean the outer lens. Use of other chemicals could result in premature lens cracking (crazing) and discoloration. Lenses in this condition have significantly reduced effectiveness and should be replaced immediately. Inspect and operate this product regularly to confirm its proper operation and mounting condition. Do not use a pressure washer to clean this product.
- It is recommended that these instructions be stored in a safe place and referred to when performing maintenance and/or reinstallation of this product.
- **FAILURE TO FOLLOW THESE SAFETY PRECAUTIONS AND INSTRUCTIONS COULD RESULT IN DAMAGE TO THE PRODUCT OR VEHICLE AND/OR SERIOUS INJURY TO YOU AND YOUR PASSENGERS!**

Introduction...

The Whelen LiFe model LF35 portable scene light features a Lithium Iron Phosphate (LiFePO₄) battery. This type of battery provides efficient and long-lasting energy using the safest, most environmentally friendly technology available. In addition, Lithium Iron Phosphate batteries are capable of up to 5 times as many charge cycles as traditional Lithium Ion (LiCoO₂) batteries!

For maximum battery life, there are precautions that must be followed to ensure long battery life. Be sure to follow the information contained in this manual carefully.

Installation

1. Select a mounting location for the IIC (Intelligent Inductive Charger) base. The base may be mounted on any smooth, flat surface of ambient temperature. This surface can be either horizontal or vertical (provided the base is properly oriented). **IMPORTANT! The location selected must not allow the LF35 to be exposed to temperatures above 140°F or below -4°F. This will cause permanent damage to the battery and void the warranty.**
2. Position the base against the proposed mounting surface. When determining the location for the base, remember there needs to be sufficient room for the LF35 to be easily removed from and returned to the base for charging (see below). Additionally, the Release Button/Diagnostic Display needs to be clearly and readily visible.

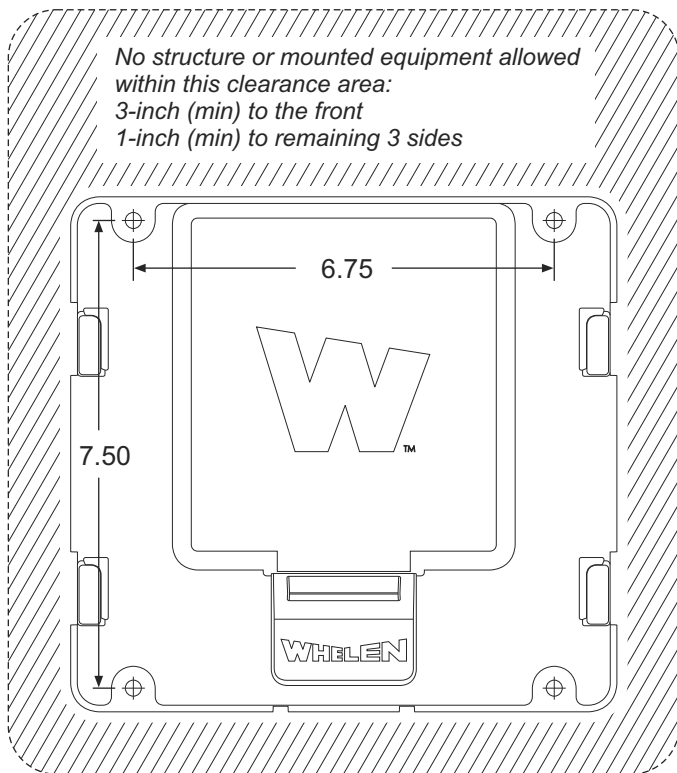

3. With the base in position, mark the locations of the four mounting holes with an awl, marker or similar tool. Remove the base from the mounting location and using a 1/4 inch bit, drill 4 mounting holes. Be sure to deburr these holes before continuing.
4. Return the base to its mounting location and using the hardware provided, secure the base to its mounting surface.

Wiring

DC chargers - Using appropriately sized wire, extend the wires coming from the base to an ignition controlled, 12VDC circuit capable of accommodating a current draw of 5 amps. The circuit used should be fused at 7.5 Amps. **IMPORTANT! Failure to use an ignition controlled circuit could, over time, result in vehicle battery drain.**

AC Chargers - AC chargers (120/240 VAC) do not require any special wiring. The base features an AC adaptor and includes a removable power cord that plugs into a standard AC receptacle.

Operation

After installation of the charging base has been completed, mount the LF35 onto the base. Orient the LF35 so that the light is facing away from the release button/diagnostic display. Place the LF35 onto the base so that the four, metal, mounting tabs are located just ahead of the mounting tab retainers. Slide the LF35 backwards until it fully engages the mounting release button with a 'click'.

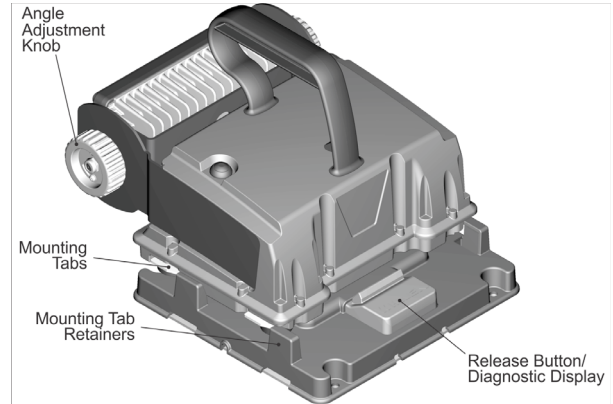

LF35 shown latched onto the charging base

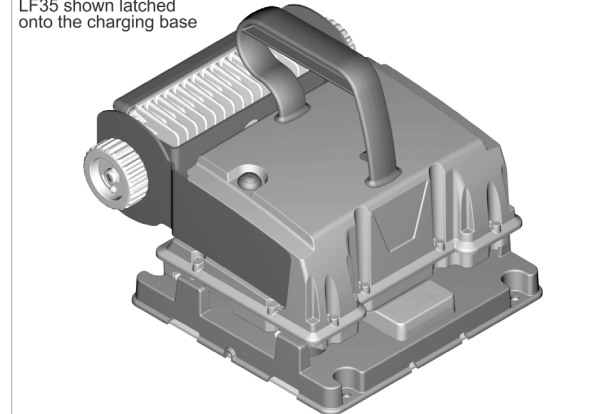

Once the LF35 is latched into position, the IIC will evaluate the battery state and report its condition by illuminating the Release Button in one of four colors. Each color represents a different property of the battery and serves to keep the user informed as to the battery's state:

- RED** - Indicates that the LF35 is properly positioned and the battery is charging.
- GREEN** - Indicates that the battery has been fully charged. **Note:** This color may remain lit for a few moments after the LF35 has been removed from the charger.
- AMBER** - Indicates that the temperature of the LF35 is outside its acceptable range (140° to -4°F). The user must immediately move the light into an area within the acceptable operating range.
- BLUE** - Alerts the user that a metal object has been placed on or near the charger and should be removed. After removal, wait for the Blue light to go out before placing the LF35 in the charger. This may take up to 30 seconds. Do not place any object other than the LF35 on the charger!

While the LF35 is on its base, the battery is being constantly monitored and charged as needed. The translucent release button doubles as the diagnostic display and provides important information about the state of the battery. **Note that the LF35 can not be activated while on the base.**

Operating Modes

The LF35 can be used in one of three operating modes. As outlined in their descriptions, the duration of each mode is estimated using a 76°F ambient temperature. As the temperature moves away in either direction, the estimated battery life will diminish. The further away it moves, the more significant the reduction of usable battery life.

The modes are as follows

High Power High power mode produces the brightest, most intense light. To turn the light on in high power mode, press and release the power button.

In this mode, a fully charged battery will last for approximately 3 hours of continuous use.

Battery Saver Battery Saver mode is used to extend battery life when a less intense light output is acceptable. To change to Battery Saver mode, turn the light on in high power, then press and hold the power button. When you see the light output has been reduced, release the button.

In this mode, a fully charged battery will last for approximately 6 hours of continuous use.

Alert Mode Alert mode produces a flashing light. To turn the light on in alert mode, with the power off, press and hold the power button until the light begins to flash.

In this mode, a fully charged battery will last for approximately 8 hours of continuous use.

IMPORTANT! While the LiFe portable light is capable of flashing, it is not a warning light!

Critical Mode When there is approximately 15 minutes of usable battery life left, the light will automatically switch to critical mode. Until the battery has been recharged, no other mode of operation is available.

During Critical mode, light output is reduced to 10% of full intensity.

When the light has switched to critical mode, it must be recharged before it can be returned to service.

ONCE THE LF35 HAS SWITCHED TO CRITICAL MODE, IT WILL TAKE APPROXIMATELY 6 HOURS TO FULLY CHARGE THE BATTERY.

	High Power	Battery Saver	Alert Mode
Estimated Duration*	3 Hours	6 Hours	7 Hours

*Duration based on a fully charged battery @ 76°F

Angle Adjustment

The angle of the projected light may be adjusted as needed by rotating the Angle Adjustment Knob. The total sweep is 180° in 15° increments.

Battery Removal / Installation

1. Remove the 12 screws securing the bottom cover to the housing. Carefully lift the bottom cover away from the housing and disconnect the harness connector from the electrical assembly.

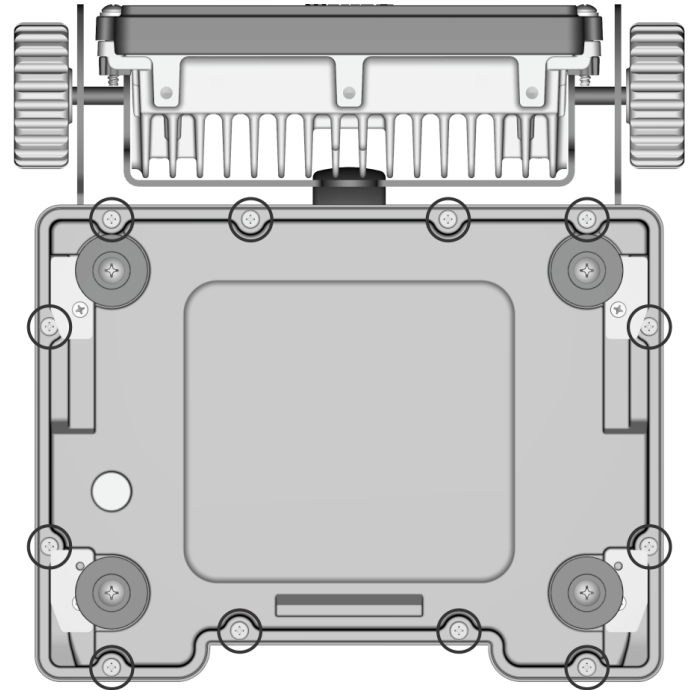

2. Remove the 7 screws securing the interior mounting plate and lift the plate out of the housing and from around the harness connector.

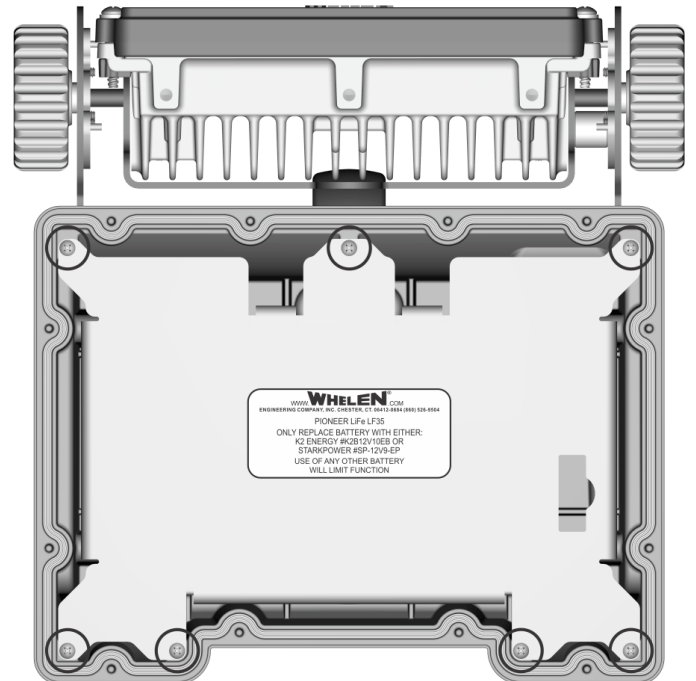

3. With the battery now accessible, remove it from the housing and disconnect the Red and Black wires from the battery terminals.

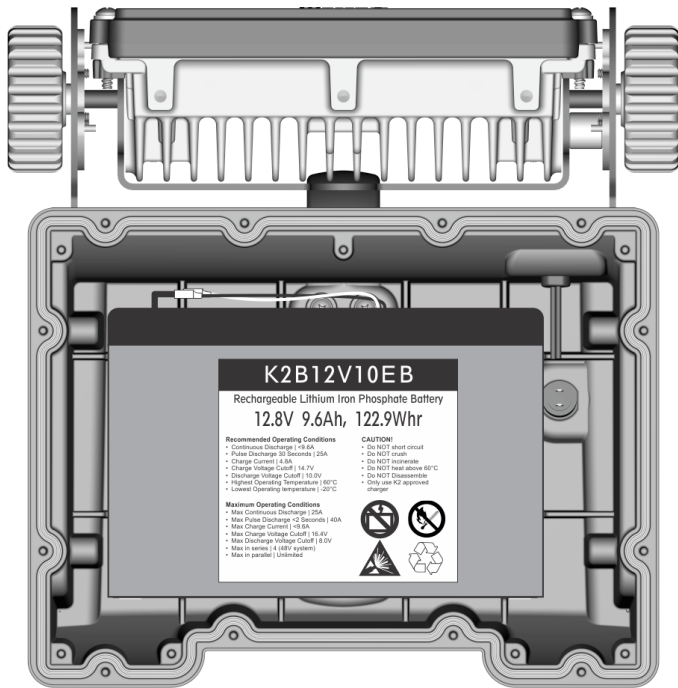

IMPORTANT! The label on the interior mounting plate lists the batteries that may be used with this product. Do not install any battery other than what is listed on this label.

4. To install a battery, connect the RED wire to the POSITIVE (+) battery terminal and connect the BLACK wire to the NEGATIVE (-) battery terminal. **CONNECTING THE WIRES TO THE WRONG TERMINAL COULD CAUSE PERMANENT DAMAGE TO THE BATTERY AND VOID THE WARRANTY!** Return the battery to its installed location.
5. Route the harness connector through its opening in the Interior Mounting Board. Position the Board in its original mounting location, making sure not to pinch any wires. Secure using the original hardware removed in step 2.
6. Connect the harness plug to the connector on the bottom cover, position the cover in its original mounting location and secure using the original hardware removed in step 2.
7. Before reinstalling the bottom cover, make sure that the gasket seal is properly positioned and not twisted. Position the cover onto the housing and secure it to the housing using the original hardware removed in step 1.
8. Place the LF35 onto its base and allow it to fully charge before returning it to service.

IMPORTANT! When the battery has reached the end of its usable life, it is important that it be disposed of safely and properly. Contact your local officials for Lithium Iron Phosphate (LiFePO₄) battery disposal guidelines and battery recycling locations for your area.

Attention!

If for any reason it becomes necessary to ship the LiFe battery, whether installed in the LiFe Light or not, there are critical shipping guidelines and procedures that need to be strictly followed. Contact your shipping company for their specific packaging and labeling requirements regarding the transportation of “Lithium Iron Phosphate” batteries.